

Welch Allyn[®]
Q-Stress[®]
CARDIAC STRESS TESTING SYSTEM
INSTALLATION MANUAL

Manufactured by Welch Allyn, Inc. Skaneateles Falls, NY U.S.A.



CAUTION: *Federal law restricts this device to sale by or on the order of a physician.*

©2020 Welch Allyn This document contains confidential information that belongs to Welch Allyn, Inc. No part of this document may be transmitted, reproduced, used, or disclosed outside of the receiving organization without the express written consent of Welch Allyn, Inc. Welch Allyn, Quinton, and Q-Stress are registered trademarks of Welch Allyn, Inc. Software V6.3.0

For patent information, please visit www.welchallyn.com/patents

For information about any Welch Allyn product, visit: <https://www.welchallyn.com/en/about-us/locations.html>

Customer Service and Technical Support: <https://www.welchallyn.com/en/other/contact-us.html> 1.888.667.8272,
mor_tech.support@hillrom.com

REF 771457; 9515-205-60-ENG Ver H
Revision date 2020-03

901144 CARDIAC STRESS TESTING SYSTEM



Welch Allyn, Inc.
4341 State Street Road
Skaneateles Falls, NY 13153 USA

www.welchallyn.com

EC REP EU IMPORTER

Welch Allyn Limited
Navan Business Park, Dublin Road,
Navan, Co. Meath C15 AW22
Ireland

TABLE OF CONTENTS

SCOPE	2
HARDWARE CONNECTIONS	2
USE OF AN UNINTERRUPTABLE POWER SUPPLY (OPTIONAL)	2
SYSTEM CONFIGURATION.....	3
EQUIPMENT SYMBOLS AND MARKINGS	5
DEVICE SYMBOL DELINEATION	5
STRESS CART ASSEMBLY	6
CART PARTS AND OPTIONS.....	7
CART ASSEMBLY STEPS.....	11
INSTALLATION OF SYSTEM COMPONENTS	21
STEP 1 - INSTALLING THE ISOLATION TRANSFORMER.....	21
STEP 2 - INSTALLING THE COMPUTER.....	22
STEP 3 - INSTALLING FRONT END MODULES	24
STEP 3 - INSTALLING FRONT END MODULES (CONTINUED)	25
STEP 3 - INSTALLING FRONT END MODULES (CONTINUED)	26
STEP 3 - INSTALLING FRONT END MODULES (CONTINUED)	27
RJ45 AND LAN ISOLATION ADAPTER CONNECTIONS (OPTIONAL).....	28
STEP 4 - INSTALLING A LASER PRINTER (OPTIONAL).....	29
STEP 5 - INSTALLING A THERMAL WRITER	30
STEP 6 - DISPLAY ASSEMBLY	32
STEP 6 - DISPLAY ASSEMBLY (CONTINUED)	33
STEP 6 DISPLAY ASSEMBLY (CONTINUED)	34
STEP 6 DISPLAY ASSEMBLY (CONTINUED)	37
STEP 7 ORGANIZING THE CABLES	43
SUPPORTING INFORMATION	44
COMPLETED Q-STRESS SYSTEM WITH THE LCD AND TANGO M2 MOUNTED	44
CONNECT THE EXERCISE DEVICE	45
FRONT-END COMPONENTS	46
Q-STRESS SOFTWARE INSTALLATION AND CONFIGURATION	47
Q-STRESS SOFTWARE INSTALLATION PROCESS	49
ACTIVATE THE Q-STRESS SOFTWARE	53

TABLE OF FIGURES

FIGURE 1 STRESS SYSTEM COMPONENTS.....	3
FIGURE 2 EXAMPLE OF A STRESS CART WITH THE Z200+ THERMAL WRITER, TANGO M2, AND TOUCH MONITOR	6
FIGURE 3 EXAMPLE OF A STRESS CART WITH A WINDOWS LASERJET PRINTER, TANGO M2, AND TOUCH MONITOR	6

SCOPE

This document describes the assembly of a Stress system. It is designed to be used as a whole for the installation process or in part as a troubleshooting tool for ensuring correct connection, configuration, and functioning of the Stress system.

Because the Stress system can be purchased in different configurations and with different options, your system's feature set may be different from the feature set shown in this document.

Read all instructions before you begin the installation process. Follow the instructions in the order given.

If you have any questions regarding execution of these instructions, contact technical support at:

- ◆ 1.888.667.8272
- ◆ mor_tech.support@hillrom.com

Hardware Connections



Caution. The following cautions apply:

The computer, display, and printer must be plugged into the isolation transformer. The optional Tango BP monitor may also be plugged into the isolation transformer.

The isolation transformer must be plugged into a dedicated circuit.

The treadmill must be plugged into a dedicated circuit.

Use of an Uninterruptable Power Supply (Optional)

If you use an uninterruptable power supply (UPS), insert it between the isolation transformer and the computer and monitor.



WARNING! Electronic interference.

The AM12Q and Trigger modules can be installed in the stress cart, mounted on the treadmill handrail utilizing a custom treadmill rail clamp kit, or in another convenient location. The AM12Q front end should be installed in a location that prevents the patient cable to be in close proximity to power cords, transformers, or other powered devices to minimize the possibility to introduce noise into the ECG signal.

System Configuration

The block diagram (Figure 1) shows a typical configuration and suggested locations for connection of the various system hardware components. Your system will be similar but may not be identical to the configuration shown. Contact technical support with any questions.



WARNING! Electronic interference.

Grounding reliability can be achieved only when equipment is connected to a properly-grounded receptacle. Ensure that the isolation transformer is connected to this type of electrical outlet.

Figure 1 Stress System Components

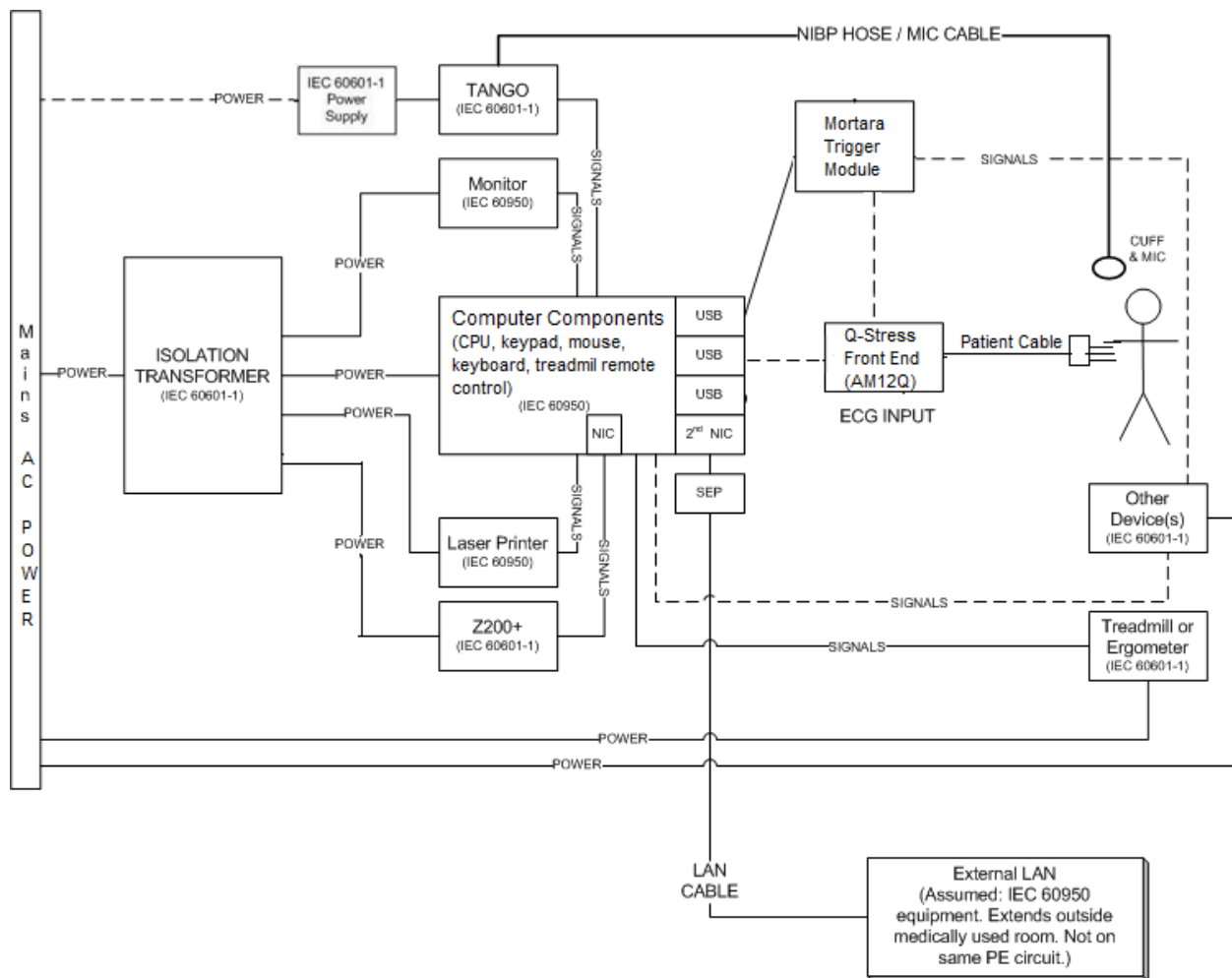

NOTE: There is a power switch on the front of the computer that must be pressed to boot up the computer. Turn off the computer by shutting down Windows.

***NOTE:** The Certified Separating Device (Isolation Transformer) will power up to four devices. When more than four devices require power, the Tango BP Monitor must be powered by another available AC power outlet. The SunTech Tango unit does not require connection to the isolation transformer, as it is a medical device that includes its own isolated power supply. The Tango may be powered by the isolation transformer as a convenience.*

Make a note of which ports are used to connect the treadmill, ergometer, and blood pressure monitor. You will need this information to configure the Stress software.



Caution. Treadmill/Ergometer communication.

Power Management should be disabled for USB ports to prevent USB ports from being powered down. This is beneficial for maintaining communication with the treadmill or ergometer exercise equipment.

EQUIPMENT SYMBOLS AND MARKINGS

Device Symbol Delineation



WARNING The warning statements in this manual identify conditions or practices that could lead to illness, injury, or death. In addition, when used on a patient applied part, this symbol indicates defibrillation protection is in the cables. Warning symbols will appear with a grey background in a black and white document



CAUTION The caution statements in this manual identify conditions or practices that could result in damage to the equipment or other property, or loss of data



Follow instructions/directions for use (DFU) -- mandatory action. A copy of the DFU is available on this website. A printed copy of the DFU can be ordered from Welch Allyn for delivery within 7 calendar days.



Indicates compliance to applicable European Union directives



Medical Device



Model Identifier



Reorder Number

STRESS CART ASSEMBLY

The steps below show how to place Stress system components on a Stress cart. If you are not placing your system on a cart, you can use these steps for instructions on connecting the different components.

Figure 2 Example of a Stress Cart with the Z200+ Thermal Writer, Tango M2, and Touch Monitor



Figure 3 Example of a Stress Cart with a Windows LaserJet Printer, Tango M2, and Touch Monitor



Caution. Unstable workstation.

For best results, place the system equipment on the cart as described in these instructions.

All carts require the following three component kits:

- Base
- Work surface
- Display mount and blood pressure monitor mount

Stress carts may include accessories such as:

- SunTech Tango BP monitor mount
- Storage solutions
- Workflow solutions

Each cart assembly kit includes tools and hardware necessary for assembly.

Cart Parts and Options

Cart Base (9911-023-45)

Content and appearance may vary based on options ordered.

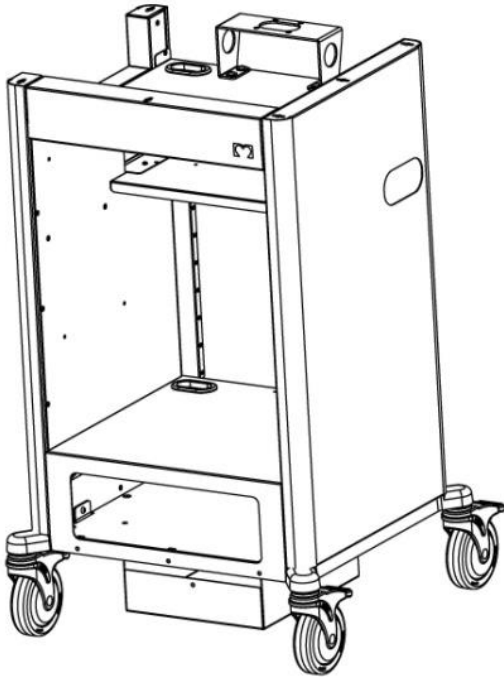

Front



Back Panel shown, no longer included



Z200+ Work Surface and Accessories

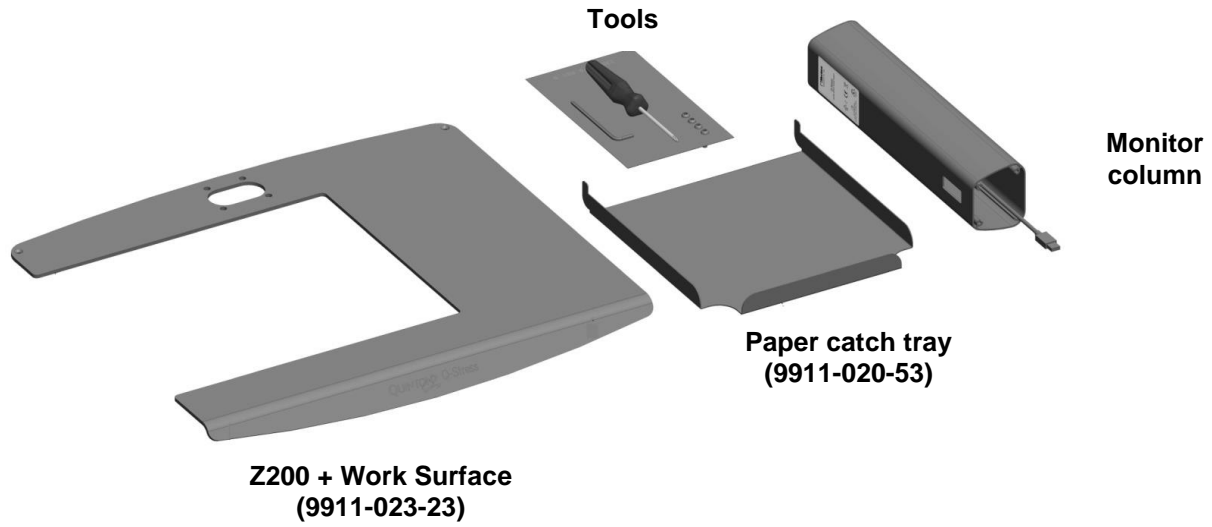

Standard Display Mount supports LCD or Touch Monitor (9911-023-31)

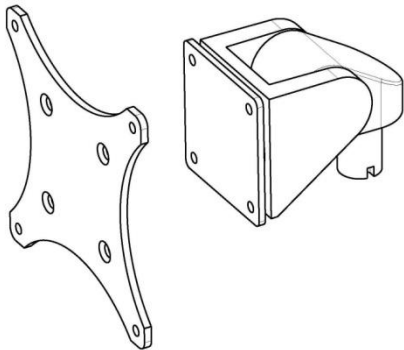

SunTech Tango Mount Kit for Standard 24" LCD display (9911-023-32)



SunTech Tango Mount Kit for 24" Touch Monitor Display (9911-023-33)

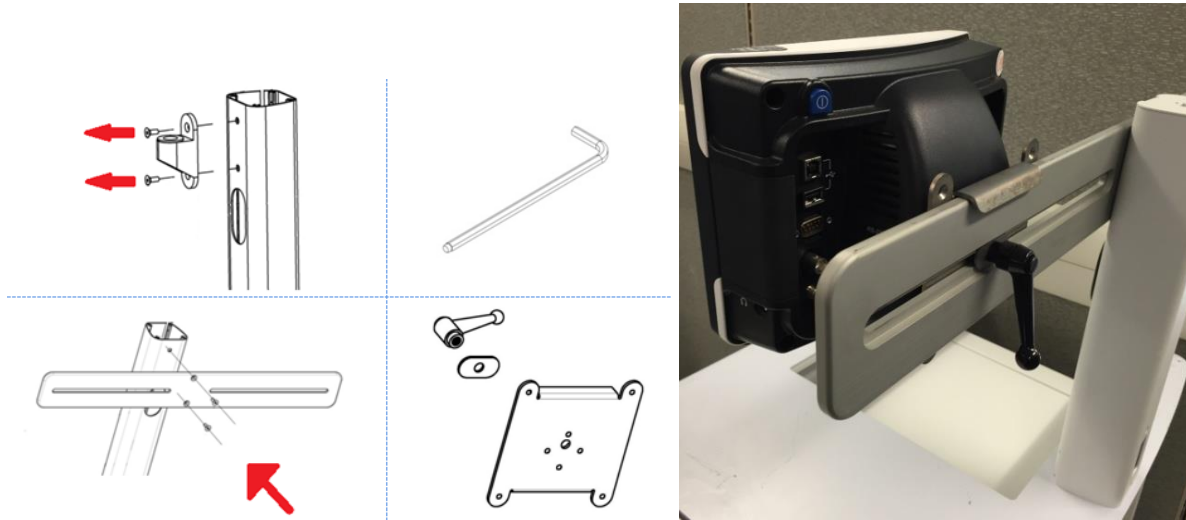

Slide Out Keyboard Tray (9911-023-44)



Storage Drawer (9911-023-41)

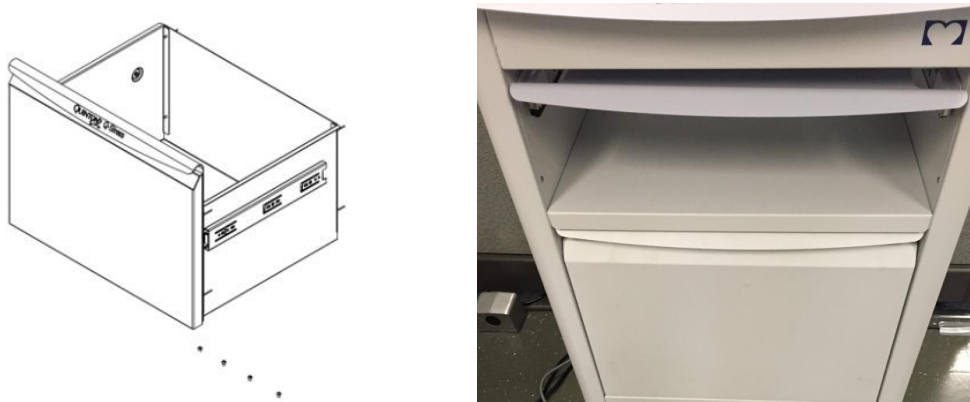

Storage Accessories (9911-023-42)

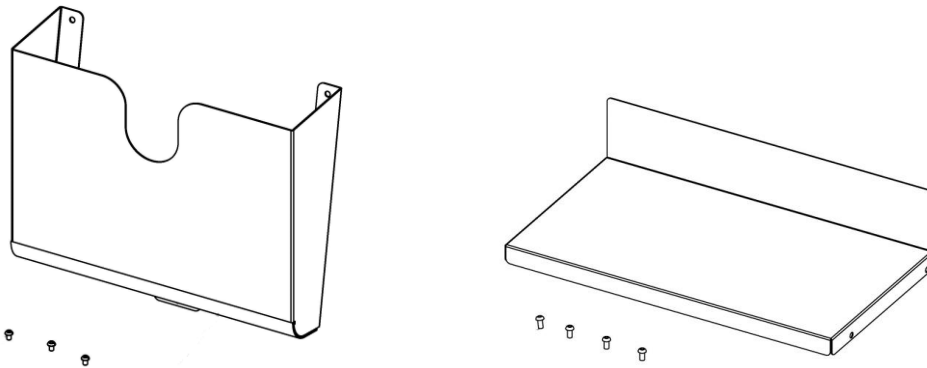

WAM Holder (9911-023-43)



Surface Extension side shelf (9911-023-24)

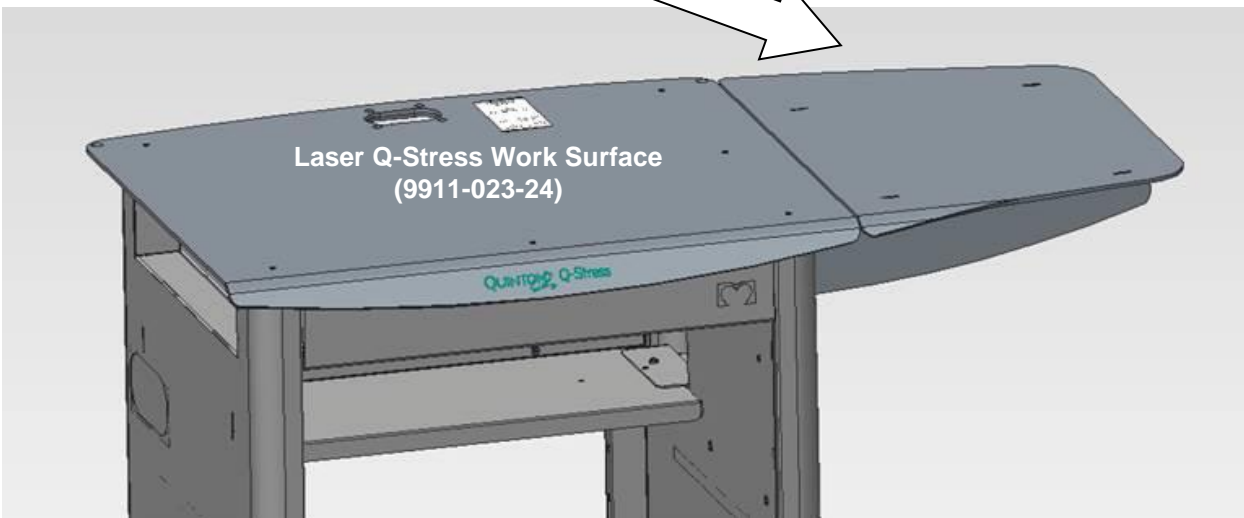

Cart Assembly Steps

STEP 1 - Uncrate the base



- Lift the shipping carton off cart base

- Unpack ramp
- Roll cart base off shipping pallet

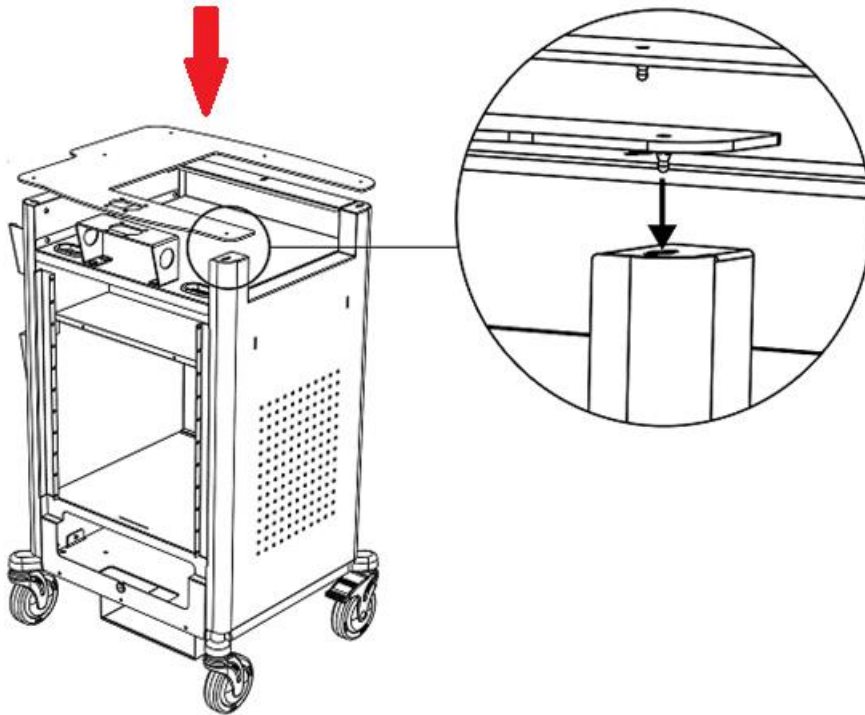
STEP 2 - Assemble work surface onto base

- Lift the cutout desktop onto the cart assembly aligning the fasteners with the precut holes.
- Apply moderate pressure to snap the lock fasteners in place.
- Ensure that all 6 lock fasteners are securely fastened.

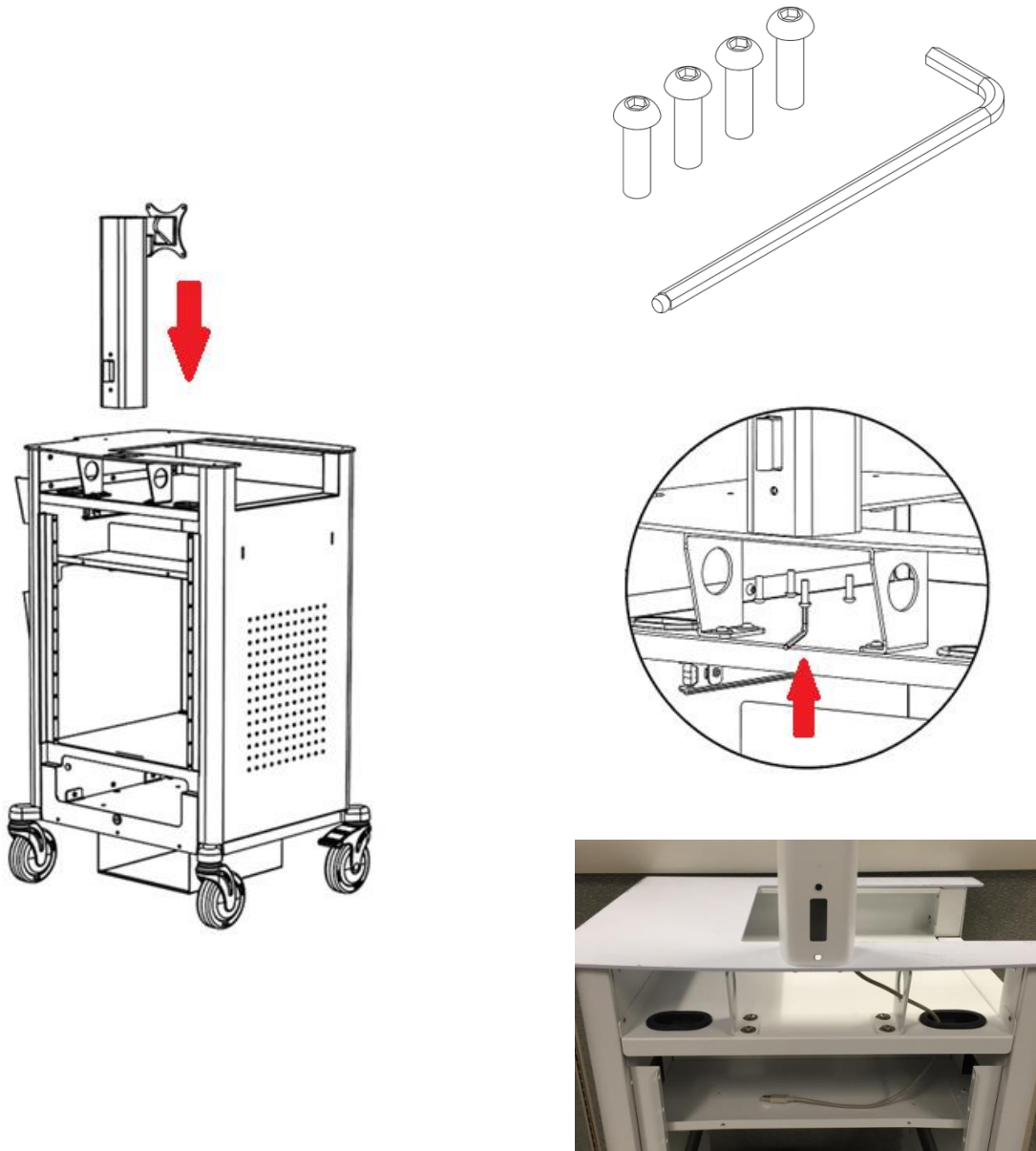
STEP 3 - Fasten display mount to work surface

- Align the monitor mount with the four screw holes in the desk top.
- Fasten the monitor mount assembly to the cart with four M6 X 20 mm screws using the supplied Allen wrench.
- Route ECG B USB cable (typically beige in color) as shown in photo above. This cable will later connect to the Trigger Module ECG B port.

STEP 4 - Display mount assembly

For units with 24" LCD display

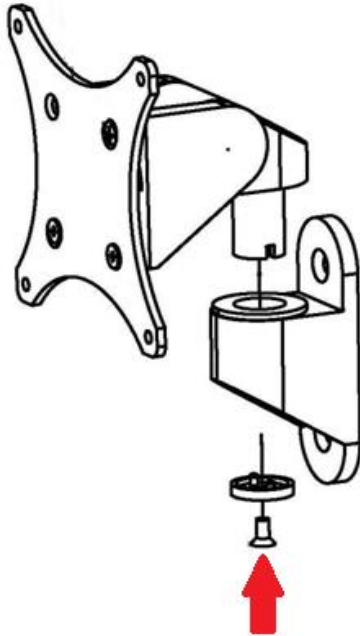

- Use #2 Philips screw driver to remove the LCD mounting bracket off of the swivel mount, then install the LCD mounting bracket onto the mounting post of the stress cart.
- Remove the 4 screws from the mounting holes on the back of the monitor and set aside (as they are not needed).
- Attach the swivel mount to the back of the monitor using the screws that came with the mounting bracket.
If a Tango BP Mounting Arm not included with the installation, add 2 washers to each mounting screw to avoid damaging the monitor.
- If a Tango BP mounting arm is included, move the Tango BP monitor mounting arm off to side until LCD is ready to be fastened to bracket. Take care to avoid misplacing fasteners.



STEP 4 - Display mount assembly (continued)

For units with 24" ELO Touch Monitor display

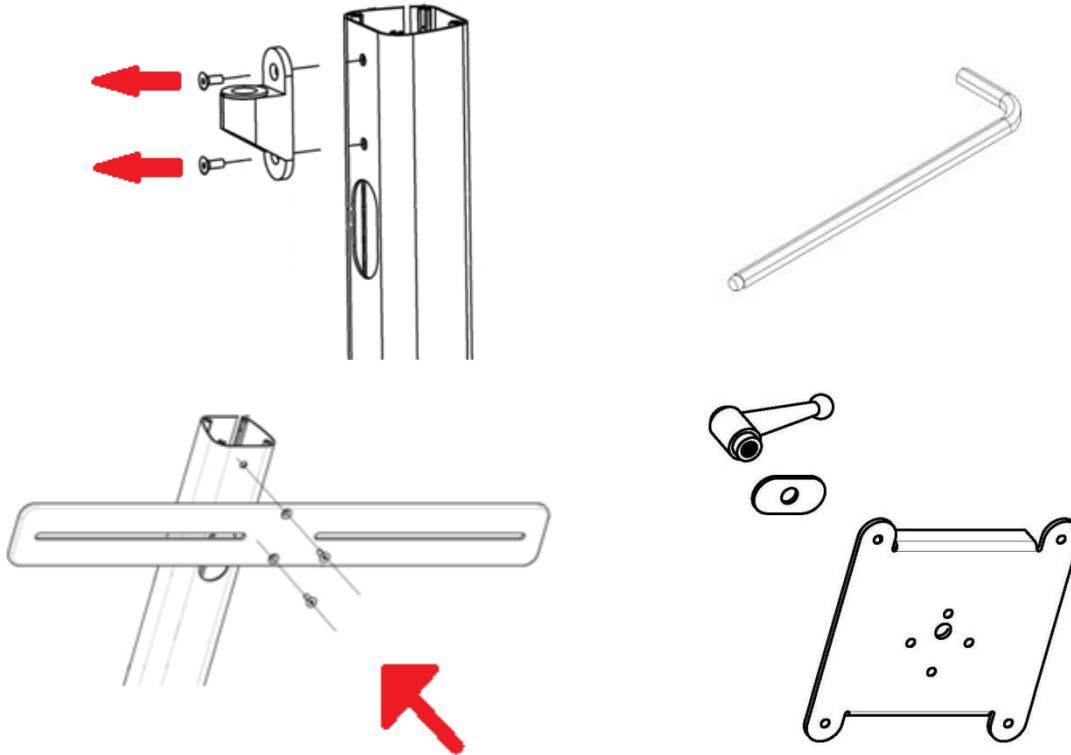

- Use 4mm Allen wrench to remove socket from display mount.
- Use 4mm Allen wrench to fasten the LCD/blood pressure crossbar to the mounting post. **(only if a Tango unit is included and additional moveable side mount tango arm not used)**
- Attach the LCD bracket to the back of the monitor, then mount the monitor onto the crossbar.
- Attach the Tango unit to the right-hand side of the crossbar as shown.

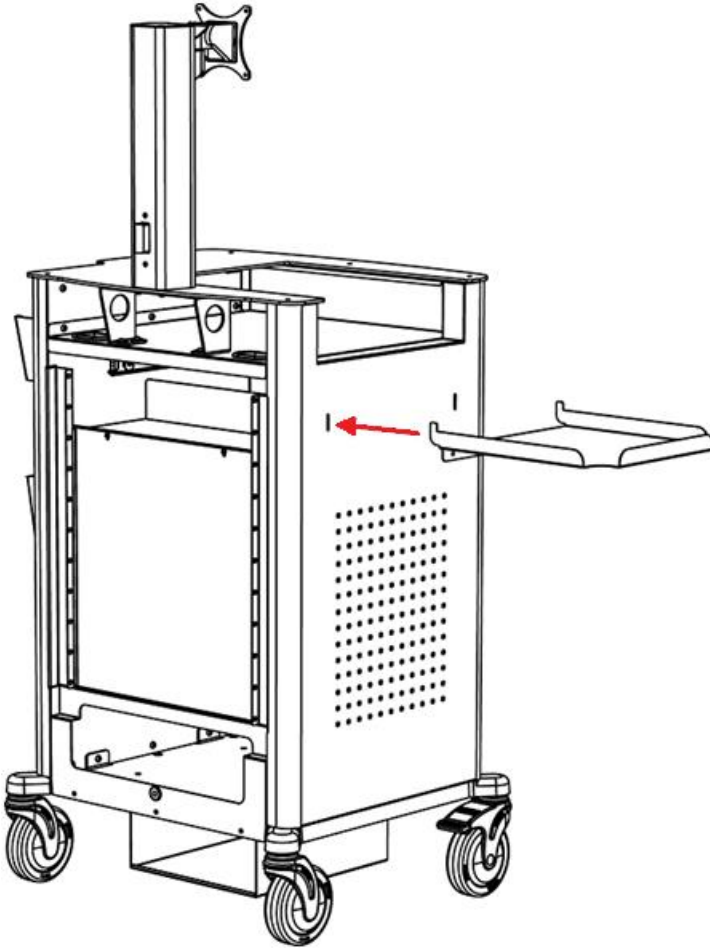

STEP 5 - Accessories, thermal printer paper catch tray

- Align the paper catch tray with the two slots on the side of the cart.
- Position the tray hooks with the tray in a 45-degree angle in the slots and bring the tray to a horizontal position so it is locked in place.

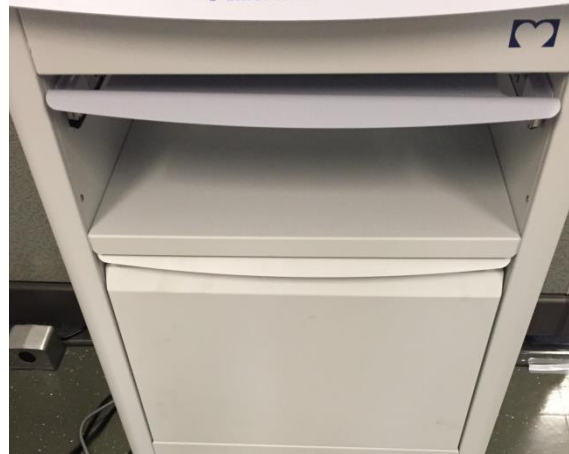
STEP 6 - Keyboard Tray and Storage Drawer

The keyboard tray and storage drawer should come pre-installed by the supplier.

Verify the tray and door slide in and out smoothly.

STEP 7 - Storage Bin

Verify the storage bin is securely fastened from the supplier.

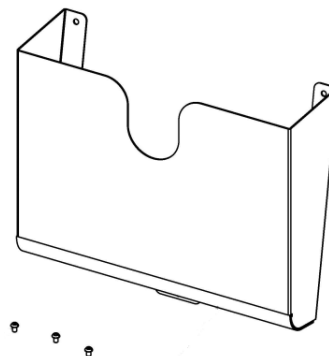
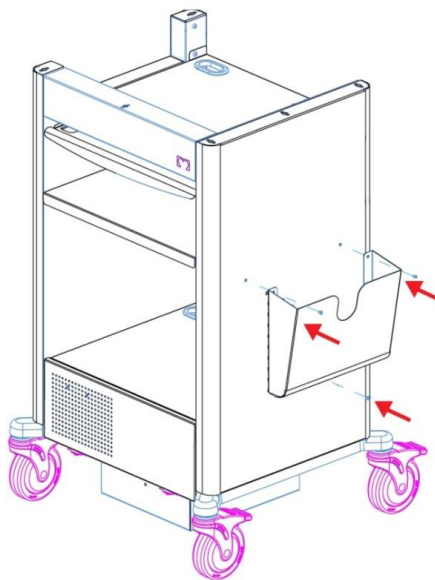

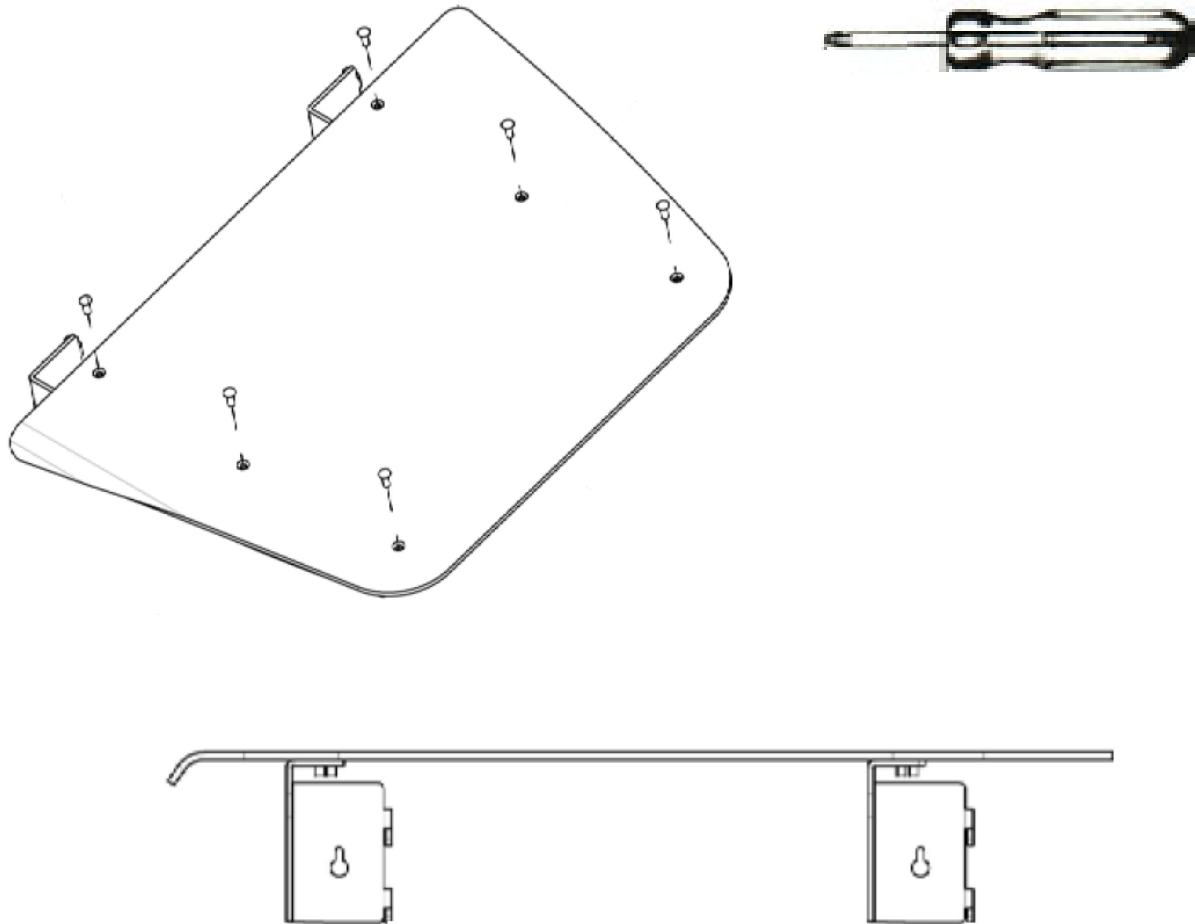
STEP 8 - Accessories, work surface extension

- Use #2 Philips screwdriver to attach the side shelf to the brackets and right side of the cart

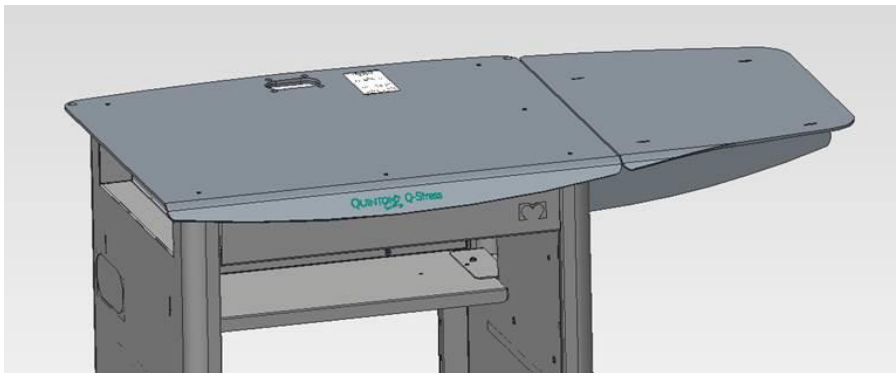

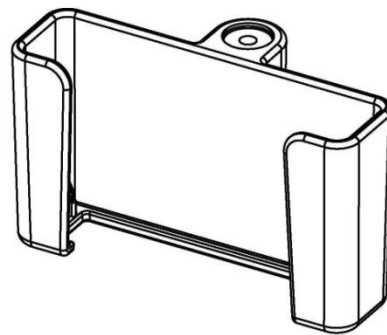
STEP 9 - Accessories, WAM holder

- The WAM holder is interchangeable side-to-side to allow customization based on options ordered and cardiac stress lab layout.
- Use #2 Philips screw driver and 8mm socket or nut driver to attach holder back corner of the cart work surface using screws provided in drawer kit.

INSTALLATION OF SYSTEM COMPONENTS

STEP 1 - Installing the isolation transformer

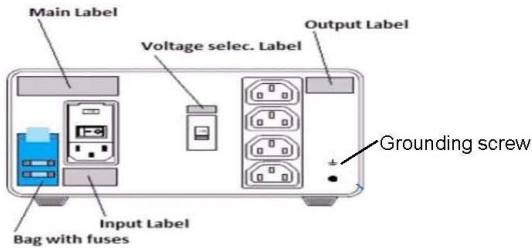

Ensure that the input and output voltage settings on the Isolation Transformer are set appropriately for the local power at 115V or 230V.

NOTE: Voltage is set at 115V when shipped from Welch Allyn.

Do not move the power switch to the on (I) position until system completely assembled and ready to test.

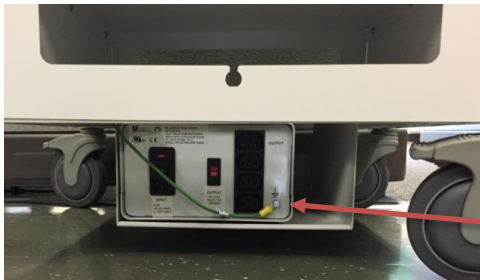

Insert the Isolation Transformer with the power entry module facing the back. Carefully slide the Isolation Transformer into the bottom opening on the back of the cart being careful not to scratch the cart.

Connect the ground wire from the stress cart to the Earth Ground Lug of the isolation transformer.



Connect the main AC Power Cord to the Isolation Transformer AC inlet as shown.



Place the plastic cord protector onto the main AC Power Cord as shown.



Insert the cord protector into the power cord cutout on the stress cart.

NOTE: Only Welch Allyn, Inc. equipment and equipment authorized by Welch Allyn, Inc. should be connected to the Isolation Transformer.

STEP 2 - Installing the computer

Slide the PC into the front of the stress cart as shown below.



All connections are to be made to the back of the computer as shown below. The **COM1** port and the network port to be used if connecting to a v1 **Z200+** via crossover cable are clearly labeled, as shown below.

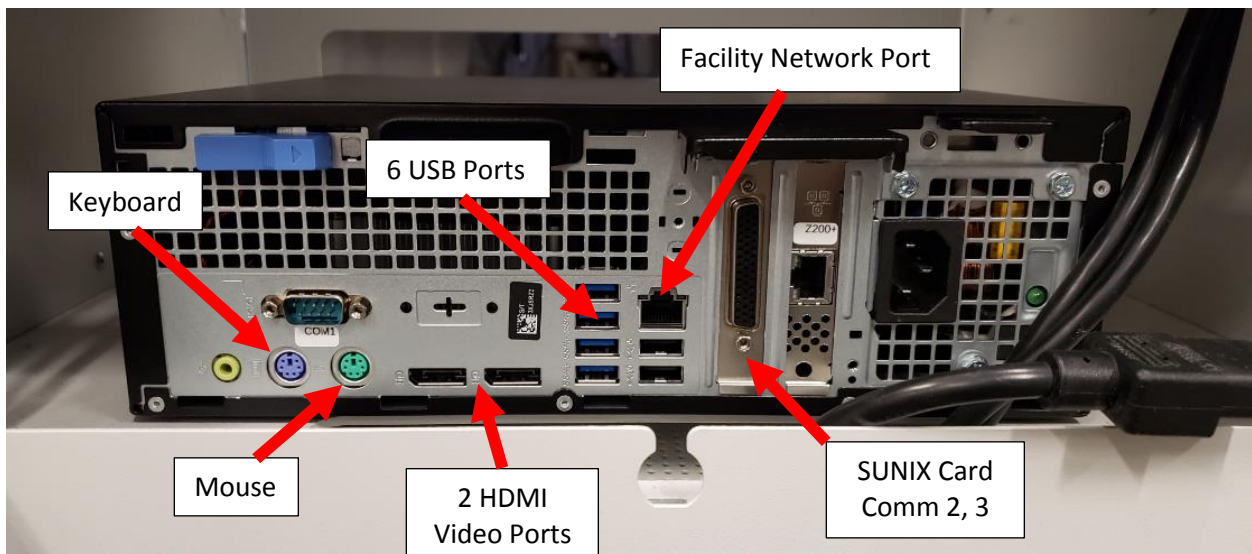

Additional communication ports (COM2, etc.) are provided via a SUNIX card (see red arrow) that will come with a splitter cable to connect additional com ports.

For units with slide out keyboard tray



Place the keyboard on the tray. Route the cable through the back of the drawer and attach the connector to the computer back.

Place mouse on work surface. Route cable through monitor mount, and attach the connector to the computer back.



Route the data cables on the right-hand side as shown and the AC power cables through the hole on the left-hand side of the stress cart.

For units without keyboard tray



Place keyboard and mouse on work surface. Route cables through monitor mount, and attach the connector to the computer back.

Use suggested cable routing from above.



Baggie contains power cables and printer cables (depending on printer version), installation instructions, software CD, user manual CD, Product ID card with serial number, and other needed accessories.

STEP 3 - Installing front end modules

Cart module bay

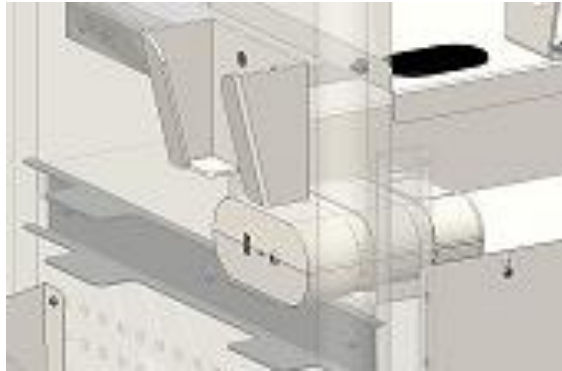

Cart base contains two module bays, one of either side. Module bays are located on shelf mounted to the back of the cart base, just under the work surface.

Modules are interchangeable side-to-side to allow customization based on options ordered and stress lab layout.

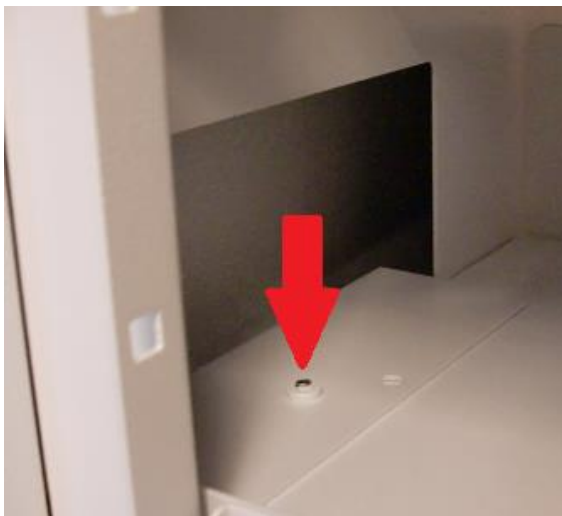

Cart base is shipped with covers over the module openings. Appropriate covers can be opened by removing fastener using a #2 Philips screwdriver.



Modules are interchangeable side-to-side to allow customization based on options ordered and stress lab layout.

Tango and AM12Q should be installed on closest side to treadmill

STEP 3 - Installing front end modules (continued)

Q-Stress AM12Q Module Installation



AM12Q is shown installed flush with cart oval cutout and patient cable connected. Make sure to install AM12Q on side of cart closest to treadmill.

(the patient cable does not need to be connected yet)



AM12Q front for patient cable connection.



AM12Q back with USB cable connection.

Module installation into cart



The modules are installed and secured with (2) screws in the upper corners of the storage compartment. Picture to left shows AM12Q and trigger module install.

When the trigger module is not included in the installation:

Connect the AM12Q to any available PC USB port.



When using Trigger Module:

Connect USB cable from back of the AM12Q to the **ECG A port** on trigger module (side facing outside of cart).

STEP 3 - Installing front end modules (continued)

For units with Trigger Module

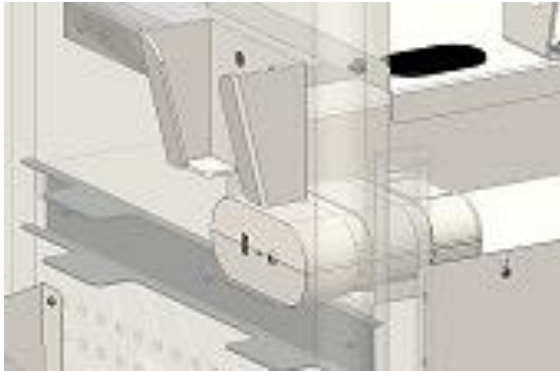

Trigger module is shown installed flush with oval cutout located on side of cart. Use side of cart farthest from the treadmill.



Trigger module front for AM12Q connection to the **ECG A** connector and one analog out connection.



The Trigger Module back has (2) **currently non-functional** analog out connections, an ECG B connector for a WAM-UTK connection, (1) TTL output connection, and a USB PC connector.

Q-Stress Front End (AM12Q) and Trigger Module Connection



Connections:

1. Connect the AM12Q output (via USB cable) to the trigger module **ECG A** input connector. These module ends are inside the stress cart.
2. Connect the trigger module output (USB cable) to any available PC USB port.
3. Connect the Q-Stress patient cable to the AM12Q front cable connector.
4. Connect other external devices to the analog/TTL connectors for ECG SYNC purposes.

STEP 3 - Installing front end modules (continued)

WAM module installation

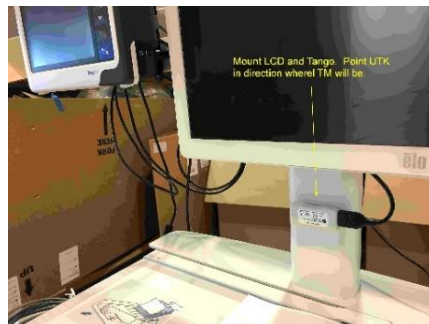

Connections:

1. Plug the 6 ft black USB extension cable into the port on the top of monitor post.
2. Plug the other end of the cable into the UTK.
3. Adhere the UTK (via Velcro) to the front of the monitor post under the LCD so it can be seen, pointing the UTK in the direction of the treadmill.
4. Plug the beige USB cable (that is hanging down from inside the monitor post) into the ECG B port on the trigger module. (The picture shows black cable in this port but the cable is typically beige)
5. Hang the WAM unit into the WAM holder.

RJ45 and LAN Isolation Adapter Connections (Optional)

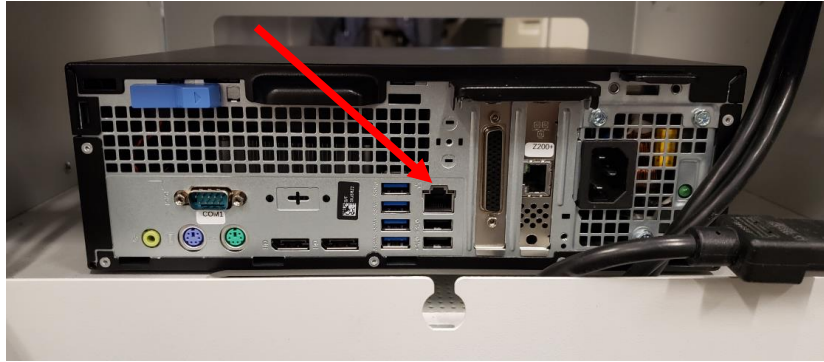

Connect the LAN isolator adapter to the Network Port (RJ45 connection) shown above right and connect the institution LAN cable to the isolator. Then use the Velcro provided to attach the isolation adapter in a convenient location, as shown above left.

Remote Keypad (Optional)



Connect the USB cable from the remote keypad to any available USB port on the back of the CPU.

Drivers will be automatically installed.

STEP 4 - Installing a Laser Printer (optional)

When a laser printer is to be installed with the Q-Stress system, place the printer on the cart as shown and route the bridge power cable to the isolation transformer. Route the printer USB cable to any available USB port on the CPU.



The cart back panel has been removed for easy access to the printer back during installation. This is done via removal of two M4 x 6 mm screws at the top of the panel.

STEP 5 - Installing a Thermal Writer

When a thermal writer is to be installed with the system, slide the Z200+ into the cutout cart desktop as shown below. Install the A4 paper spacer following included instructions if necessary.



Route the power cable for the Z200+ thermal writer through the channels and cutouts to the isolation transformer and the data communication cable (either a USB cable for Z200+ v2, or a network crossover cable for Z200+ v1).

Z200+ v1 Network Connection



If using a Z200+ with an integrated network (LAN) connector, connect the ethernet crossover cable from Z200+ thermal printer to secondary LAN card on the PC following the channels and cutouts. The LAN port used for the Z200+ should be labeled “Z200+” from the factory. (LAN connections shown above)

A crossover cable must be used for this connection and one is supplied with the system.

If using a Z200+ v2 with a USB connector, connect one end of the USB cable to the USB B connector on the Z200+ thermal printer and the other end to the USB A connector on the back of the Q-Stress PC following the channels and cutouts (see connections below).

Z200+ v2 USB Connection

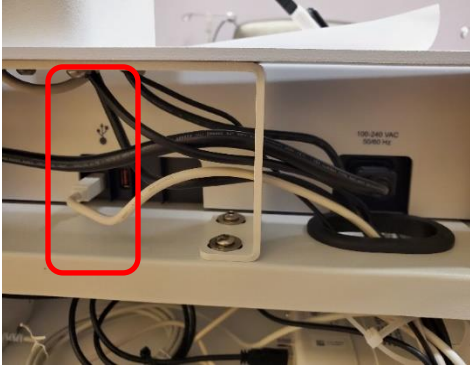

STEP 6 - Display assembly

For units with 24" LCD display

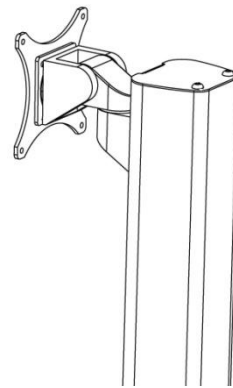

- Use #2 Philips screwdriver to attach the 24" NEC LCD display to the mounting plate of the monitor mount assembly using the screws supplied with the display. Refer to instructions supplied in the display box.
- Connect the VGA video cable to the monitor. Route cable through the monitor mount down into the PC compartment in the cart base. Connect the VGA cable to the PC by using the VGA to HDMI adapter provided with the PC.



If the monitor is supplied with a HDMI port/cable, it can be connected directly using the HDMI cable.

- Organize and secure cables per suggestions in Step 7.

STEP 6 - Display assembly (continued)

For units with 24" LCD display and blood pressure monitor arm

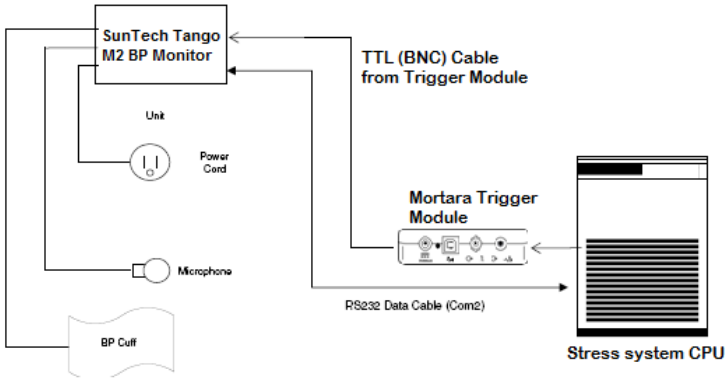
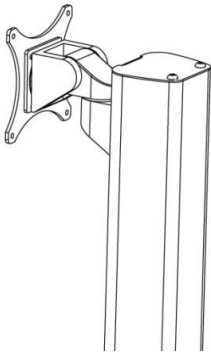

STEP 6 Display assembly (continued)

- The Tango BP monitor arm is bolted between the 24" LCD display and the monitor mount, placing the monitor at the same height and depth as the LCD.
- Tango BP monitor arm is interchangeable side-to-side to allow customization based on options ordered and cardiac stress lab layout.
- Use #2 Philips screwdriver to attach the 24" LCD display to the mounting plate of the monitor mount assembly using the screws supplied with the display. Refer to instructions supplied in the display box.
- Feed the AC power cable up through the bottom of the display post, until it comes out through the hole in the front of the post. Connect the AC power cord to the monitor and the other end to the isolation transformer.
- Connect the VGA video cable to the monitor. Route cable through the monitor mount down into the PC compartment in the cart base. Connect the VGA cable to the PC by using the VGA to HDMI adapter provided with the PC.



If the monitor is supplied with a HDMI port/cable, it can be connected directly using the HDMI cable.

- Use a #2 Philips screwdriver to attach the Tango BP monitor to the arm using the 4x 8-32 screws supplied with the arm. It may be helpful to connect the power and data cables to the monitor before fastening it to the arm.

Connecting the Tango M2

(the directions below come with the Tango unit – see box for most recent version)

1. Verify Correct RS-232 cable is present (both ends are 9 pin female connectors)

The **RS-232 Cable** enables the QStress to prompt the Tango M2 when it needs a BP measurement and allows the Tango M2 BP reading to be transferred to the QStress reports and display.

The **ECG Trigger Cable** (both ends are BNC male connections) This cable provides the ECG signal from the Xscribe to the Tango M2.

2. Connect both the RS-232 and the ECG cables to back of Tango M2 according to picture below.

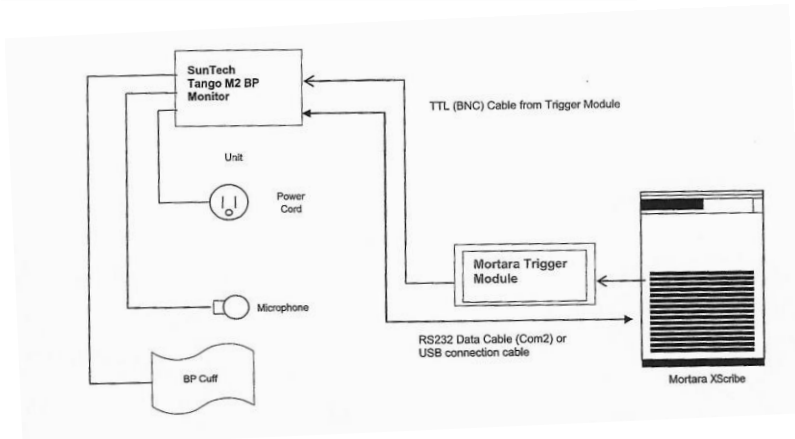
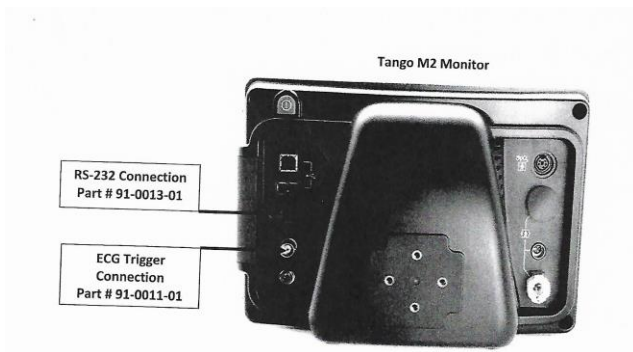

3. Connect the ECG Trigger cable from the Tango M2 monitor to the TTL connection on back of the Trigger module (if this connector is already in use a BNC splitter may be needed).

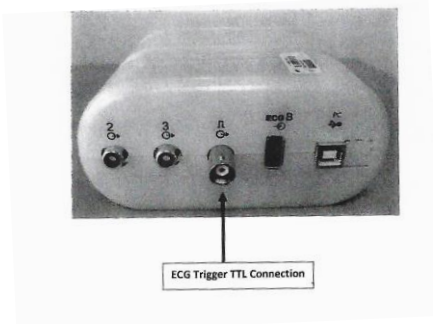

4. Connect the RS-232 Cable (9 pin connector) to the COM 2 port on back of Qstress computer.

Note: Additional communication ports (COM2, etc.) are provided via a SUNIX card that comes with a splitter cable to connect additional com port devices.



STEP 6 Display assembly (continued)

For units with 24" Touch Monitor panel display

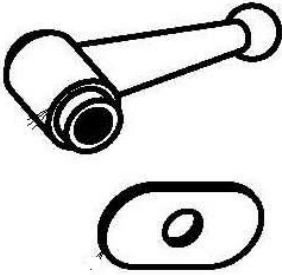
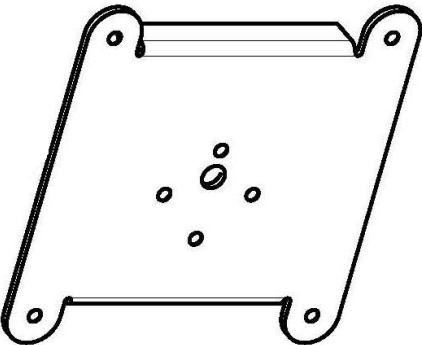
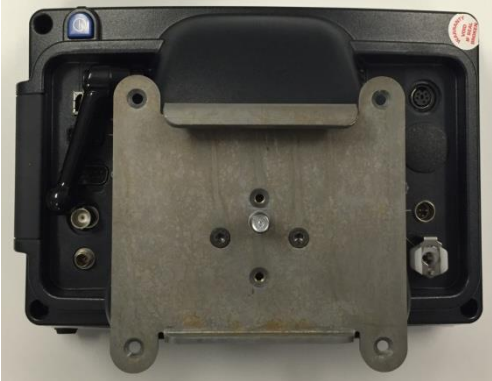

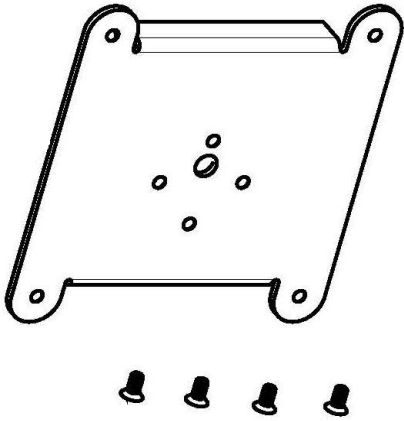
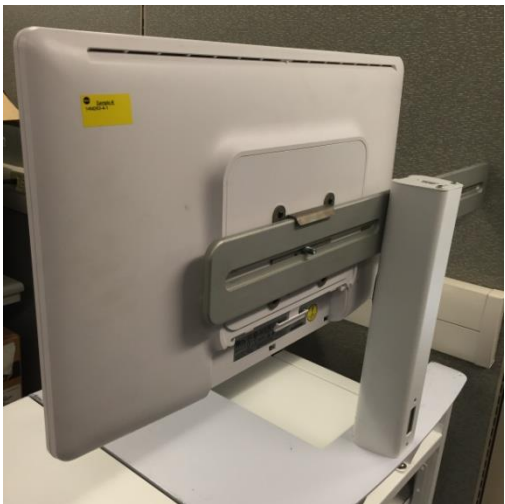
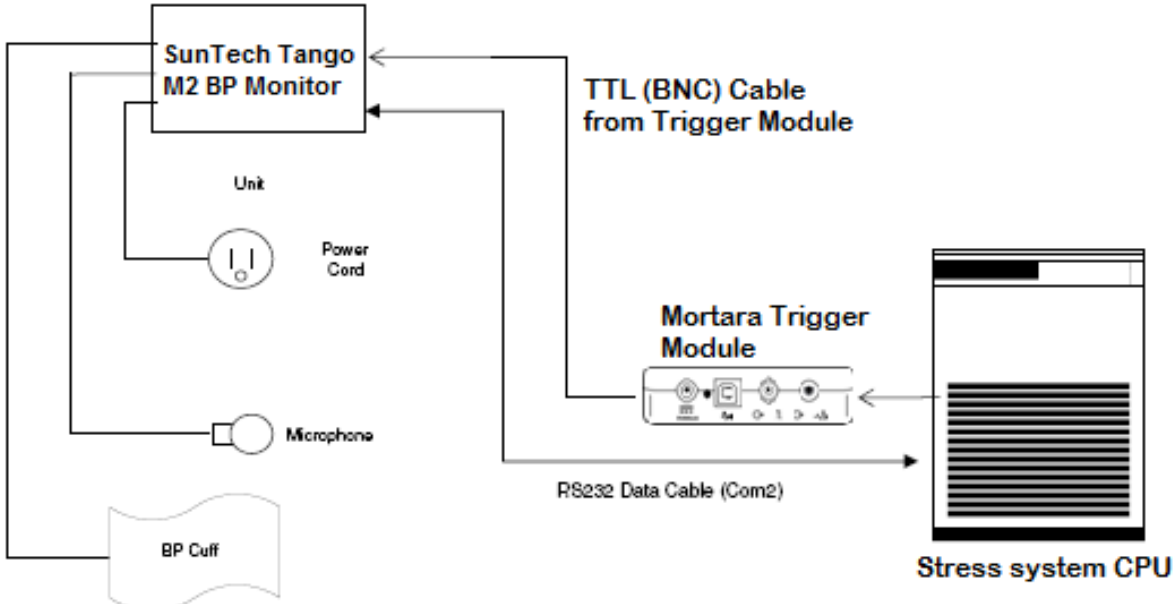

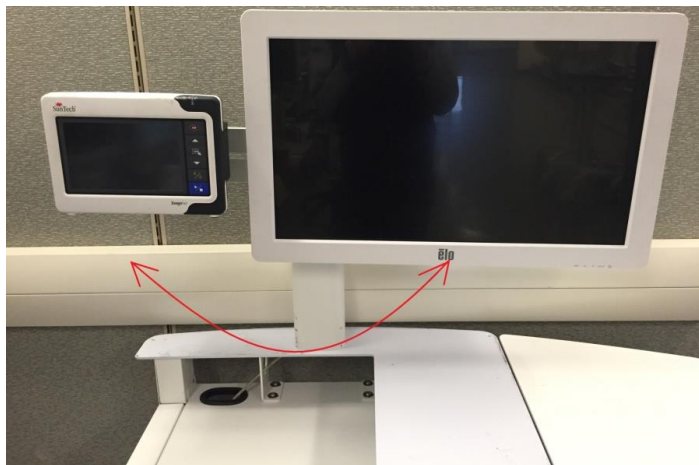
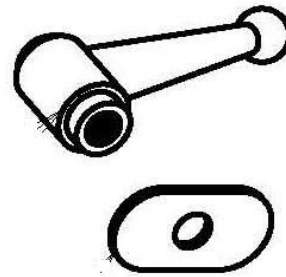
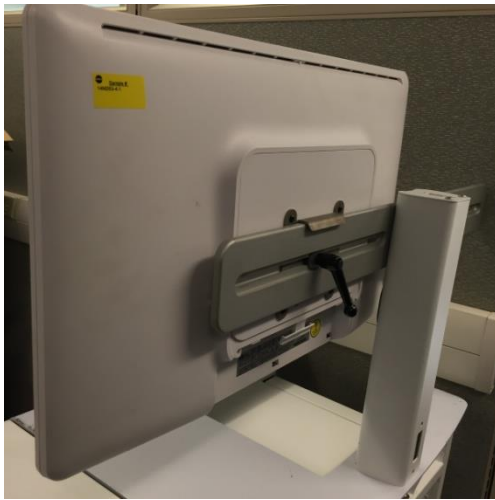

- The Tango BP monitor mount and the touch monitor display are interchangeable side-to-side to allow customization based on options ordered and cardiac stress lab layout.
- Use #2 Philips screwdriver to attach the 24" touch monitor to the mounting bracket set aside in Step 4. Use 4x M4 screws supplied with the bracket. Hang bracket on crossbar and secure with oval washer and black handle. Refer to instructions supplied in the display box.
- Remove the covers for the monitor connections from the monitor connectors.
- Feed the AC power cable up through the bottom of the display post, until it comes out through the hole in the front of the post. Connect the AC power cord to the monitor and the other end to the isolation transformer.

- Connect the VGA video cable to the monitor. Route cable through the monitor mount down into the PC compartment in the cart base. Connect the VGA cable to the PC by using the VGA to HDMI adapter provided with the PC.



If the monitor is supplied with a HDMI port/cable, it can be connected directly using the HDMI cable.

- Connect the USB cable to the monitor. Route the cable through the monitor mount into PC compartment in the stress cart base. Connect the other end to a USB port on the back of the PC.



- Use a #2 Philips screwdriver to attach the blood pressure monitor to the arm using the 4x 8-32 screws supplied with the arm. It may be helpful to connect power and data cables to the monitor before fastening to the arm. Hang bracket on crossbar and secure with black handle.

Connecting the Tango M2

(the directions below come with the Tango unit – see box for most recent version)

1. Verify Correct RS-232 cable is present (both ends are 9 pin female connectors)

The **RS-232 Cable** enables the QStress to prompt the Tango M2 when it needs a BP measurement and allows the Tango M2 BP reading to be transferred to the QStress reports and display.

The **ECG Trigger Cable** (both ends are BNC male connections) This cable provides the ECG signal from the Xscribe to the Tango M2.

5. Connect both the RS-232 and the ECG cables to back of Tango M2 according to picture below.

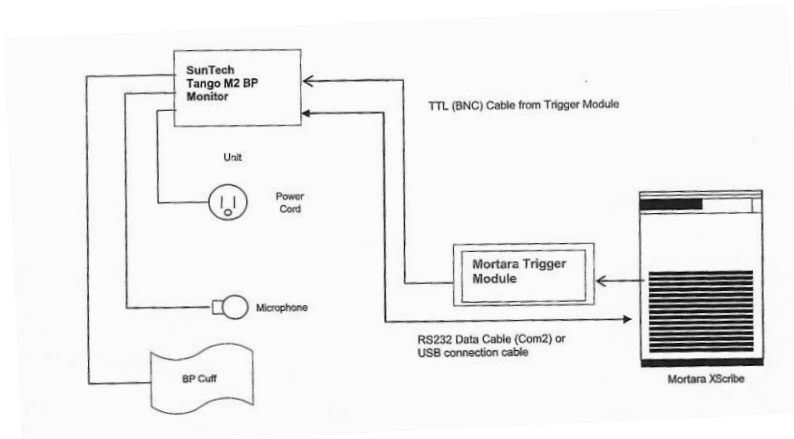
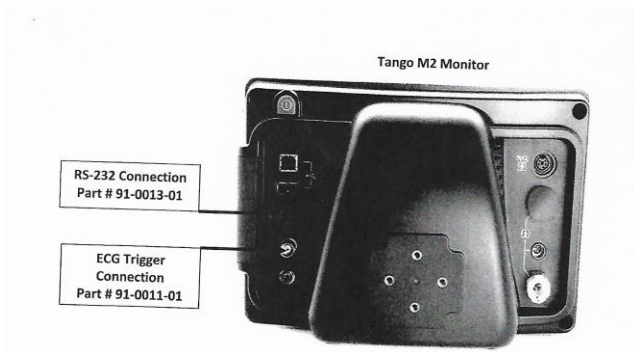

6. Connect the ECG Trigger cable from the Tango M2 monitor to the TTL connection on back of the Trigger module (if this connector is already in use a BNC splitter may be needed).

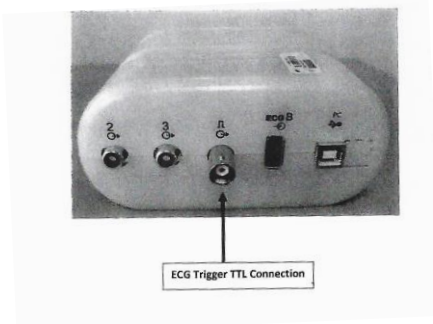

7. Connect the RS-232 Cable (9 pin connector) to the COM 2 port on back of Qstress computer.

Note: Additional communication ports (COM2, etc.) are provided via a SUNIX card that comes with a splitter cable to connect additional com port devices.

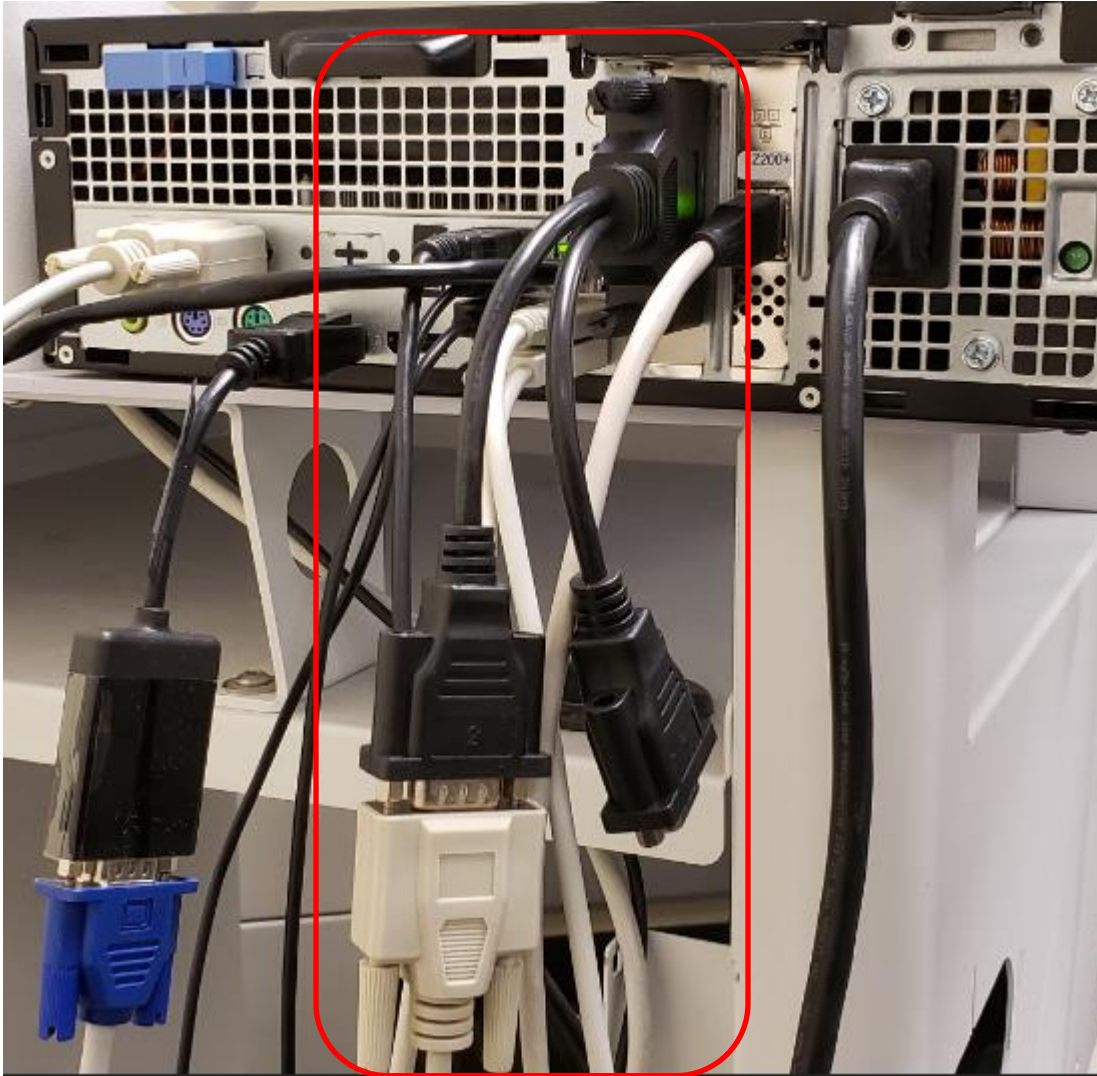

STEP 7 Organizing the Cables



Organize the cables neatly at the cart back, routing them through the cable channels, secured with nylon tie wraps.

Depending on the installation and options, choose one side of the cart base to run power cables and the other to run signal (USB, VGA, RS-232, etc.) cables. This will reduce the interference from the power lines.

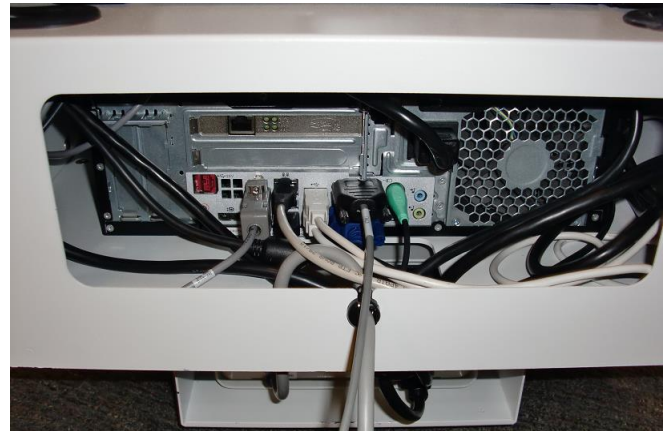

- Route the keyboard cable through the cutout in the keyboard tray back to the rear CPU connection.
- Route the mouse cable from the desktop down to the rear CPU connection.

Leave all extra parts and cables inside the QSTRESS drawer

(if the Customer needs to change configurations later, they will need these pieces)

Supporting Information



The system serial number is available in the Programs menu (Start → All Programs → Mortara Modality Manager → Modality Manager Activation Tool) and is also on the Product Identification card label.

User manuals are electronically available on the included User Manual CD. The appropriate language PDF can be copied to the computer desktop for quick access.

The software CD is also included.

A business card with your contact information can be inserted in the mouse pad pocket.

A cardiac stress lead placement and prep poster is included in a mailing tube.

Instruct the customer to place items in a safe and convenient location.

Completed Q-Stress System with the LCD and Tango M2 Mounted



Finished Cart with the Z200+ Thermal Writer configuration, 24" LCD, SunTech Tango M2 BP monitor and Computer components installed.

Connect the Exercise Device

Treadmill

Connect the treadmill to the computer **COM1** port via the Serial cable provided (recommended), or via USB cable. No further preparation is needed.

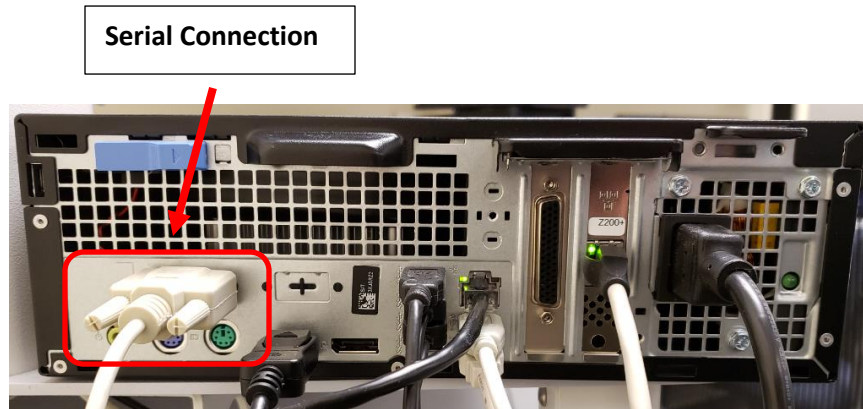

Note: Additional communication ports (COM2, etc.) are provided via a SUNIX card that will come with a splitter cable to connect additional com port devices.

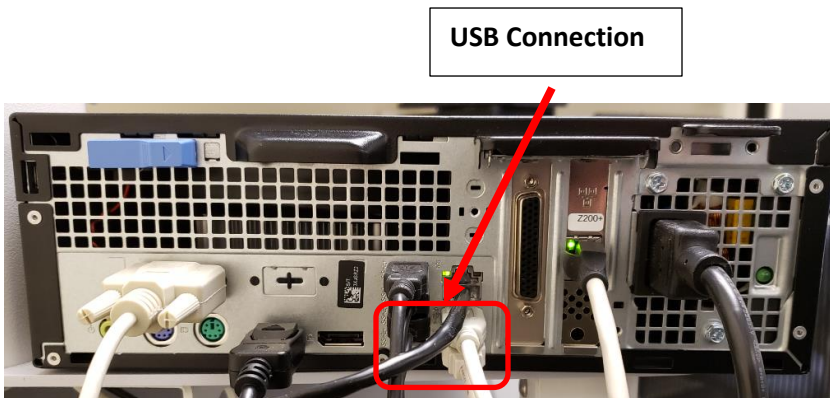

Ergometer

Use the instructions that came with the ergometer device to connect it to the Stress computer.

Front-End Components

Material Supplied for Installation

AM12Q Components

- Q-Stress Front End, AM12Q, Module (9293-062-50)
- USB Trunk Cable AM12 (8358-003-50, Qty 1)
- Q-Stress 43" AHA Patient Cable (60-00184-01)

Trigger Module (optional) includes

- Trigger Module (30012-024-50, Qty 1)
- Cable USB Type A-to-B Full Speed (6400-012)

Optional Kit for Wireless ECG Acquisition

Optional WAM Kit (41000-036-50) includes

- WAM (30012-019-54)
- UTK module with USB extension cable (30012-021-51 and 6400-015)
- Carry Case with Belt (8485-026-50)
- WAM holder for stress cart attachment (9911-023-43)

Optional Kits for Module Installation on the Treadmill Rail

Optional TM55/TM65 Rail Clamp Kits for the AM12Q and the Trigger Module

- AM12Q Rail Clamp Kit (9911-021-50)
- Trigger Module Rail Clamp Kit (9911-022-50)

Q-Stress Software Installation and Configuration

When a turnkey standalone configuration is purchased, software installation and activation are performed at the factory prior to system shipment.

When a distributed configuration consisting of client workstations, review stations, and server systems is purchased, software installation is performed on-site by authorized Welch Allyn personnel. Refer to the following pages for instruction.

Refer to the *Q-Stress User Manual (9515-205-50-ENG)* for instructions on how to configure and operate the cardiac stress testing application.

System Setup (Windows 10 PC)

Do not power on the system.

AC Power Setup

Ensure that the input and output voltage settings on the isolation transformer are set appropriately for the local power at 115V or 230V.

Verify that all components to be connected to the isolation transformer are able to accept the specified output voltage. Reconfigure any components that require manual input voltage adjustments.

NOTE: Some components are auto switching and do not require you to set the proper voltage.

Then move the power switch to the on (I) position.

Field Service Configuration Items:

1. Check/Change Date and Time
 - Type control panel in search bar
 - Select Clock, Language, and Region
 - Click on Set time and date (blue text underneath DATE and TIME)
 - Select Time zone and pick correct time zone for customer location.
 - If time still not correct, Select Change date and time and enter correct time and date

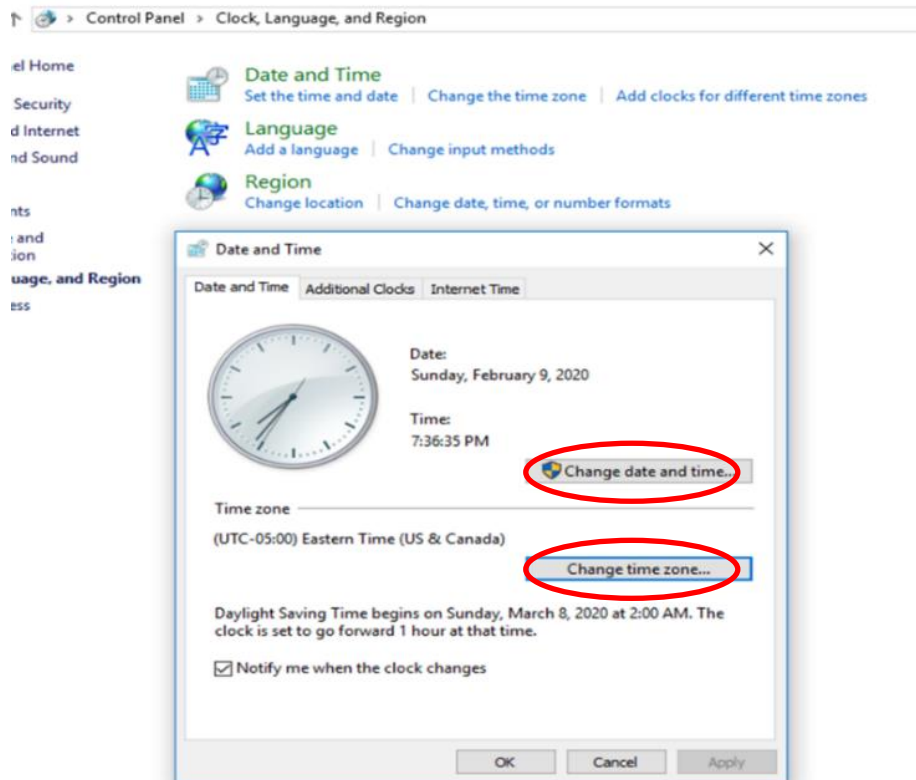

Q-Stress Software Installation Process

(only used for distributed systems, not factory installed and activated, skip both the software application installation and activation sections if factory provided)

Log in to Windows with an account having Local Administrator privileges. Navigate to the location of the software to be installed and double-click on the “**Setup**” application file. If asked to allow the program to make changes to the computer, click “**Yes**”.

Q-Stress Dialog

You are then prompted to install **Mortara PDF** on your machine if it is not already present. Click the “**Install**” button.

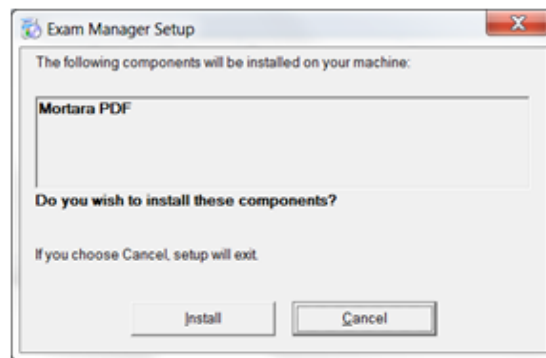

The setup wizard window will appear. Click “**Next**” to continue.

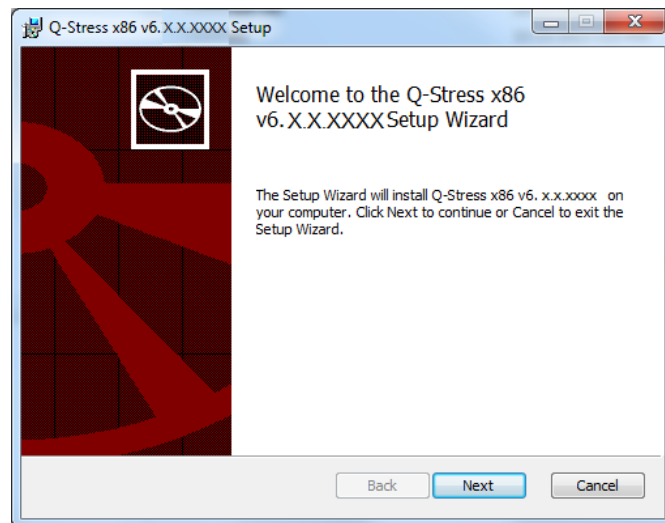

Q-Stress Dialog

Select the **Standalone** button in the Choose Setup Type dialog as shown to install a Standalone Workstation.

Click “**Next**” to continue.

When installing a dedicated server, networked client workstation, or Review Station, follow the displayed menu prompts.

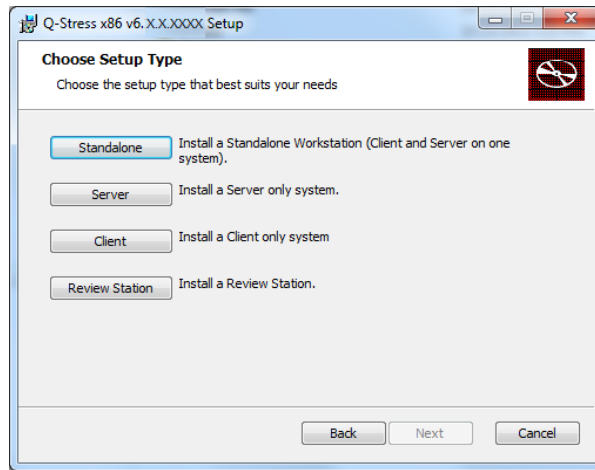

Select the **Q-Stress** or **Q-Stress w/RScribe** button according to ordered options.

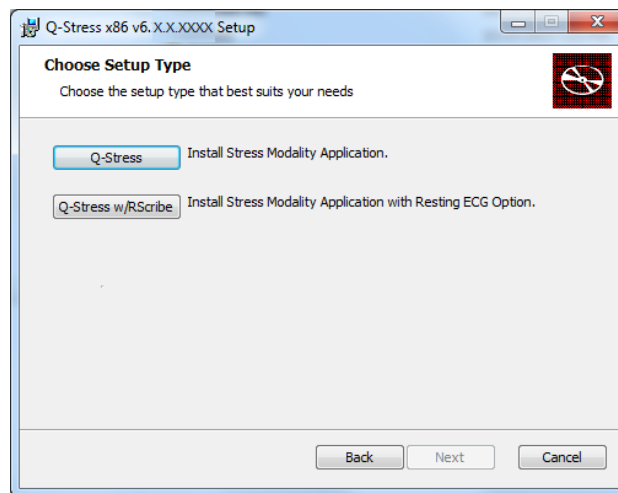

Keep selected defaults selected and click **Next** to continue unless there is any reason for change.

Selection of the **Set Database Location** button allows you to browse to a location for installation of the Q-Stress application and database other than the local default (C:\) directory.

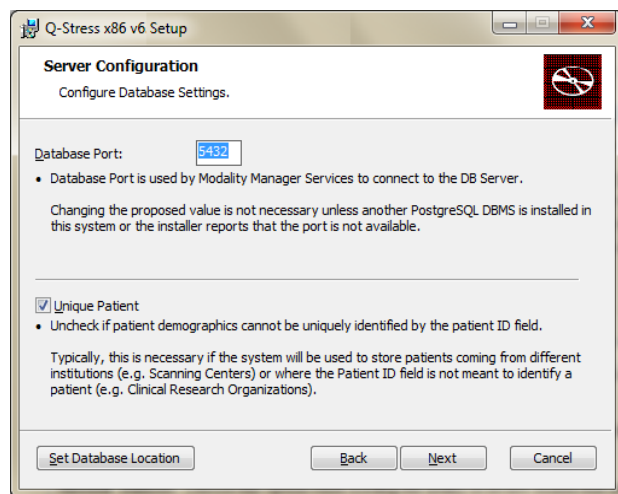

Q-Stress Dialog

With Modality Manager selected, choose the **Browse** button to navigate to the desired location for installation.

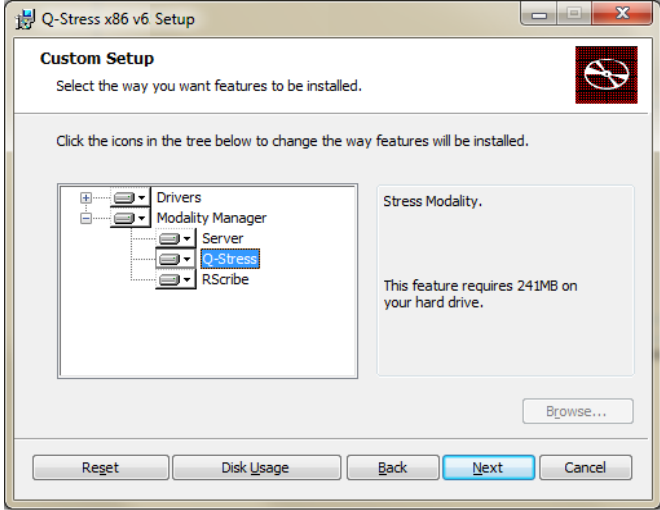

Once the selections are made, click **Next** and the Installation window will appear.

Select **“Install”** (this process takes a few minutes).

Wait while the program is being installed.

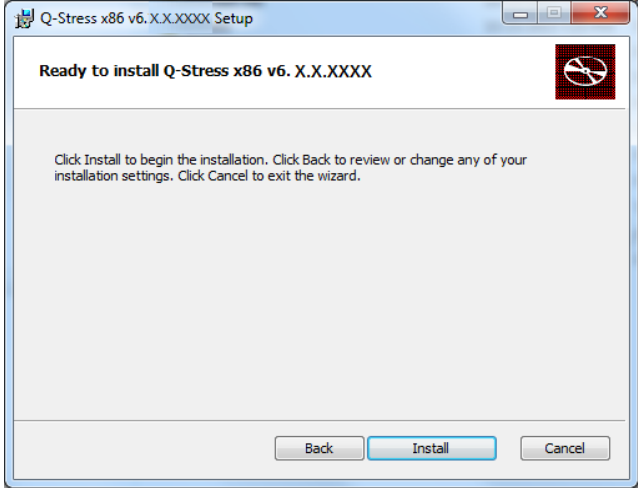

Enable **“Always trust software from Mortara Instrument, Inc.”** and then select **“Install”** to install front-end drivers.

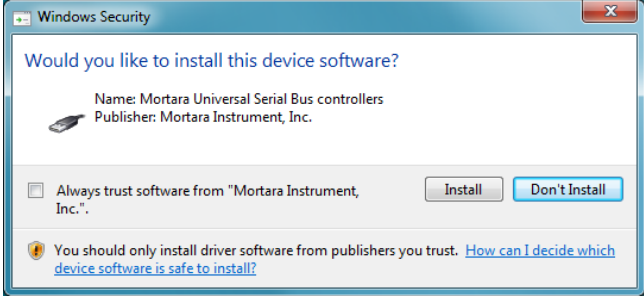

The wizard will now load the software files to the defined location and, after a while, present the Modality Manager Configuration Utility window.

All settings in this dialog should remain as default (no need for Remote slot path).

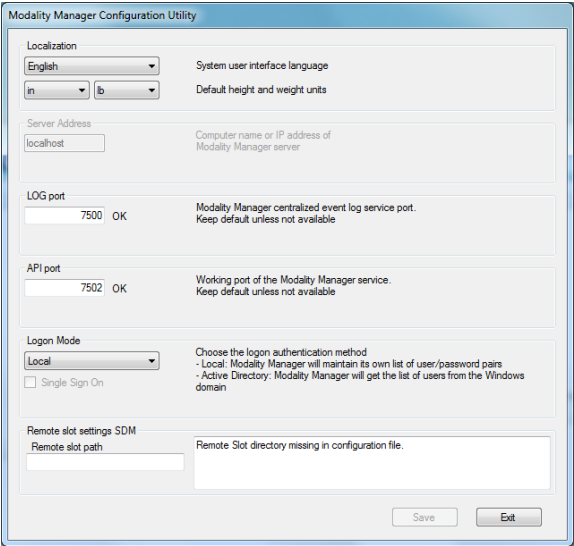

KEEP THE LANGUAGE AS ENGLISH AND THE DEFAULT SELECTIONS

Once the settings are correct, select “Exit” to continue.

Do not be concerned about the word exit. Your settings will be saved and the process will proceed to the final step of the installation.

Select “**Exit**” to continue. Wait while the program is starting services, loading samples into the database, and finishing the installation.

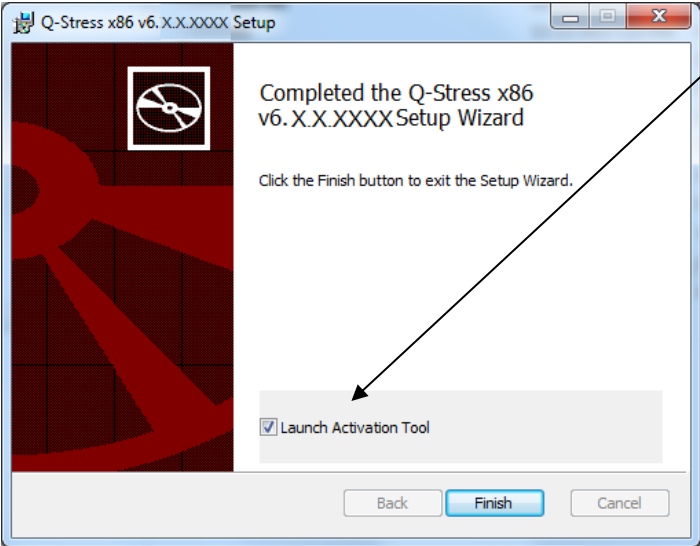

The **Launch Activation Tool** checkbox is enabled as a default and will open the dialog allowing you to request a permanent activation code.

Click on “**Finish**” to complete the installation process.

Once completed, the Q-Stress icon is available on the desktop and the program will be active for a period of 14 days.

Activate the Q-Stress software

(only used for distributed systems, not factory installed and activated, skip both the software application installation and activation sections if factory provided)

To prepare for permanent activation, navigate to the following menus if the Modality Manager Activation Tool is not already open:

- Start menu
- All Programs
- Mortara Modality Manager
- Modality Manager Activation Tool (click “Yes” when prompted to allow changes to the computer)

Enter the Q-Stress System Serial Number or the program will remain Locked or Invalid.

Enter the system serial number or numbers and then click **OK**.

Q-Stress Dialog

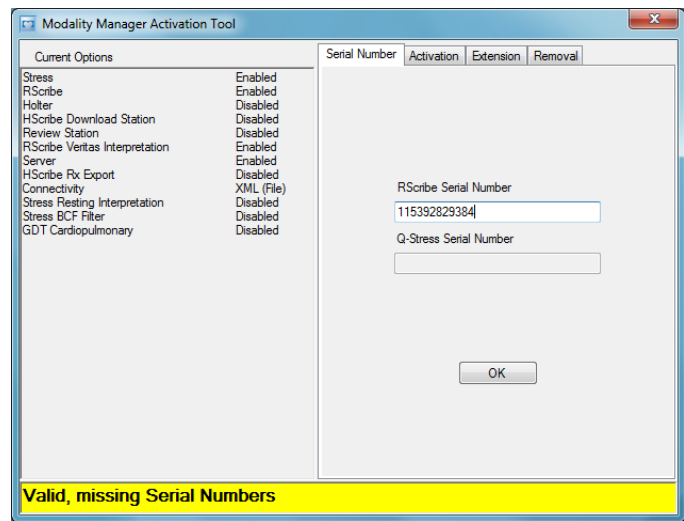

A dialog window similar to the following is displayed.

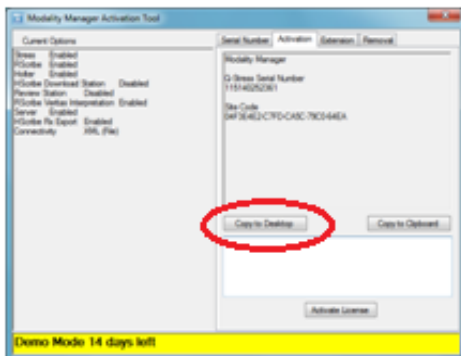

Click on the “Copy to Desktop” button and a file is sent to the CPU desktop.

Q-Stress License Activation Request

Cut and paste the file to your memory stick and then send the output file via e-mail to mor_tech.support@hillrom.com as an **Activation Request**.

Include the System Order configuration part number in the e-mail so the code will enable ordered features (e.g. QS-6BA-AAAXB).

Upon receipt of this information, an activation code will be generated by Welch Allyn Tech Support and returned to you via e-mail.

Q-Stress License Activation

Start the Modality Manager Activation Tool if the dialog is not already displayed:

- Start menu
- All Programs
- Mortara Modality Manager

Modality Manager Activation Tool (click “Yes” when prompted to allow changes to the computer)

After 14-days have passed, the program becomes invalid as shown below.

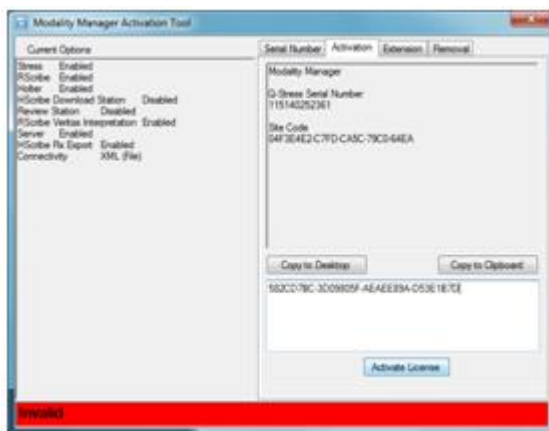

Enter the received activation code into the large text box located above the “Activate License” button.

Click the **Activate License** button and the Software License Status will show as **Valid**.



Optional Laser Printer Configuration

HP LaserJet Mx01

1. Use the installation disc that accompanies the HP Mx01 printer to install the printer.
2. Once the printer is installed, click on **Start ► Devices and Printers**. Right click on the **HP LaserJet M50x Series PCL 6** printer and then select **Printer Properties**.
3. Click on the **Advanced** tab and then select “New Driver” to add one of the following drivers based on whether the PC is a 32 bit or 64 bit system.
 - PCL5 v5.4 32bit
 - PCL5 v5.4 64 bit

NOTE: *The drivers can be found on the installation CD (QStress\Drivers\HPPCL5Drv).*

4. Once the driver is loaded, be sure it is selected from the driver menu and click **Apply**.
5. While still on the **Advanced** tab, uncheck the **Enable Advanced Printing Features** checkbox, then click **OK**.
6. Right click on the **HP LaserJet M50x Series PCL 6** printer and then select **Printing Preferences**. Click on the **Paper/Quality** tab. Under Print Quality, select **600 dpi** and then set the default paper size to **Letter** for US customers and to **A4** for International customers.
7. Right click on the **HP LaserJet M50x Series PCL 6** printer once again, select **Printer Properties**, and from the General tab click on **Print test page** and verify it prints correctly.

Optional Touch Monitor Configuration

Elo Model ET2401L Touch monitor

1. Remove the cable cover on the back of the monitor to access the connector panel.
2. Connect 4 cables from monitor to CPU: VGA, Audio input, USB touch screen output, and DC power input.



3. Reinstall the cable cover and secure with appropriate screws.
4. Then, insert the “Touch Tools Drivers and Documentation” CD that accompanies the Elo touch monitor into the computer’s CD-ROM drive. The CD should automatically run the Elo Touch Tools application. Select “Install Driver for This Computer”:



- Then, check the “install driver” box under “Elo USB Interfaces – Other Touchscreens”

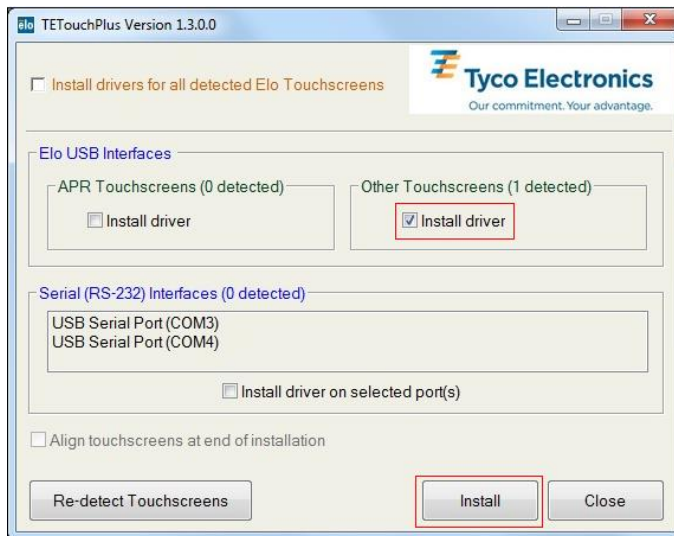

- After accepting the end-user license agreement, the drivers will finish installing. Reboot the stress system after the install is complete.

Section 3 – Q-Stress Setup

On-board Network Card IP Configuration for Z200+ Writer LAN Connection

****Note: Do not perform this step if you are installing the Z200+ printer with USB connection.**

The printer with USB connection communicates with the Proxy Service. The instruction and software to install the Proxy Service is provided on the media shipped with the Z200+ USB assembly.

1. On the Q-Stress PC, log in as Administrator.
2. Click **Start > Settings > Control Panel**.
3. Double click **Network Connections**.
4. Double click the appropriate **Local Area Network** icon. The Local Area Connection Properties dialog box will appear.
5. In the items list, select **Internet Protocol (TCP/IP)**, and click **Properties**. The Properties dialog box will appear.

Network settings are:

IP Address: 192.168.10.100
Subnet Mask: 255.255.255.0
Default Gateway: 192.168.10.1

6. Click OK in each dialog box to save the entries and exit.

Tango M2Monitor Setup (refer to instructions included in box with Tango unit for more details)

1. When the operating screen is displayed, press the SELECT button once. This will bring up the MAIN MENU screen.
2. Using Up and Down arrows, highlight MONITOR SET UP and press SELECT button.
3. Using the UP and Down arrows, highlight STRESS SYSTEM and press SELECT button.
4. Using the UP and DOWN arrows, scroll through the list until X-SCRIBE is highlighted and press SELECT button.
5. Using the UP and DOWN arrows, select EXIT twice to return to operating screen

Section 4 – Test Q-Stress Basic Functions

Double-Click the Q-Stress icon to open the program.

The first time you login (both Username and Password: **admin**), you will need to select the **System Configuration** icon to setup full access to all functions.

*** Most all program icons are unavailable (gray) until you do this. ***

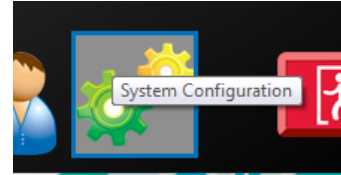

Select the **User's Database** button and you will see the "IT Admin" user. Double-click on the name to open the role privileges and check all functions.

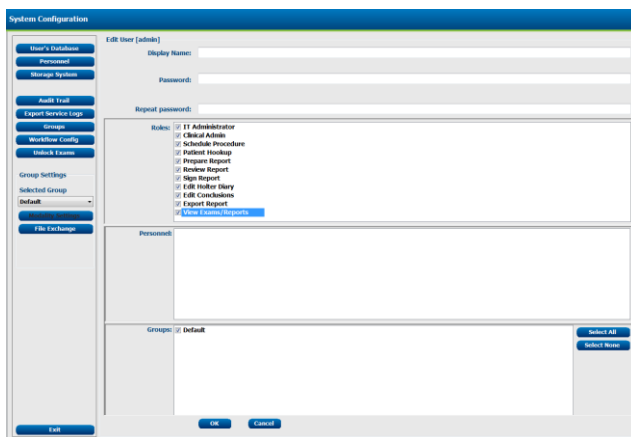

Click **OK** → **Exit** → **Exit** and start up the Q-Stress program again.

Select the **System Configuration** icon and then the **Modality Settings** and the **Printout** tab. Set the Printer Type to **Z200+** under ECG Print, Event Print, and Continuous Print. Select the **Save Changes** and then **Exit** buttons.

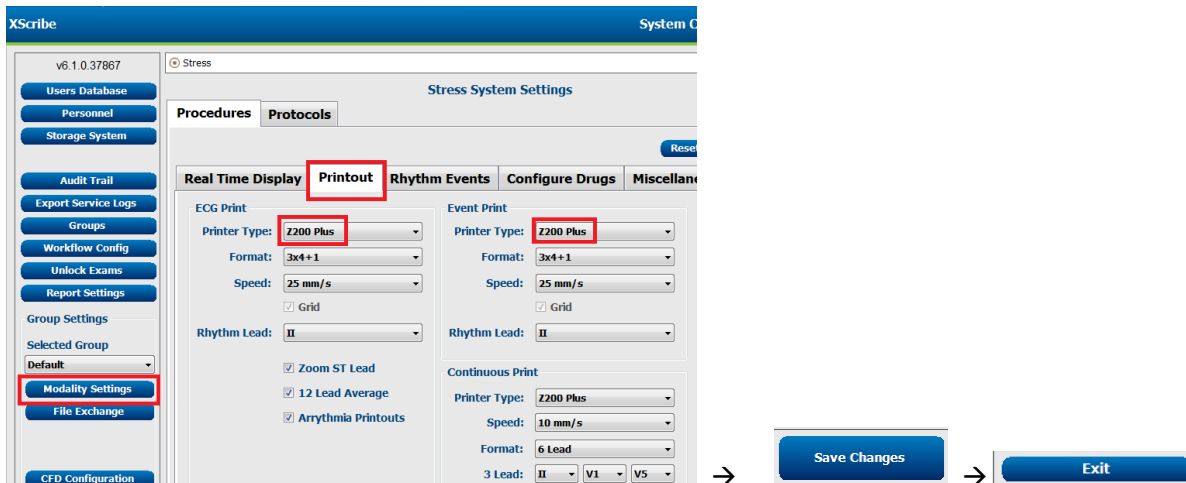

Pairing the WAM (required if WAM part of install)

- Hook WAM up to simulator (need picture)
- Click on this icon  to **Start a Stress Test**.

Then enter **Test** in the Last Name field and **112233** in the ID field.



Q-Stress Sta

Exam Information

Last Name: First Name:

Middle Name: Gender: Race:

DOB: Age: Years

Height: in Weight: lb

ID: Second ID:

Admission ID:

Address: City:

Postal Code: State: Country:

Home Telephone: Work Telephone:

Mobile Telephone: Email Address:

Angina: History of MI:

Prior Cath: Prior CABG:

Smoking: Diabetic:

Family History: Pacemaker:

Indications:

Medications:

Referring Physician: Notes:

Procedure type: Location:

Max HR: bpm Target HR: bpm

Max Workload: W Target Workload: W

Technician: Attending Phy:

MWL Patients

Patient ID

Then, select the **Start Exam** button.

Select the **Settings** icon (Gear box) in the upper left corner of the display to open the Local Settings window.

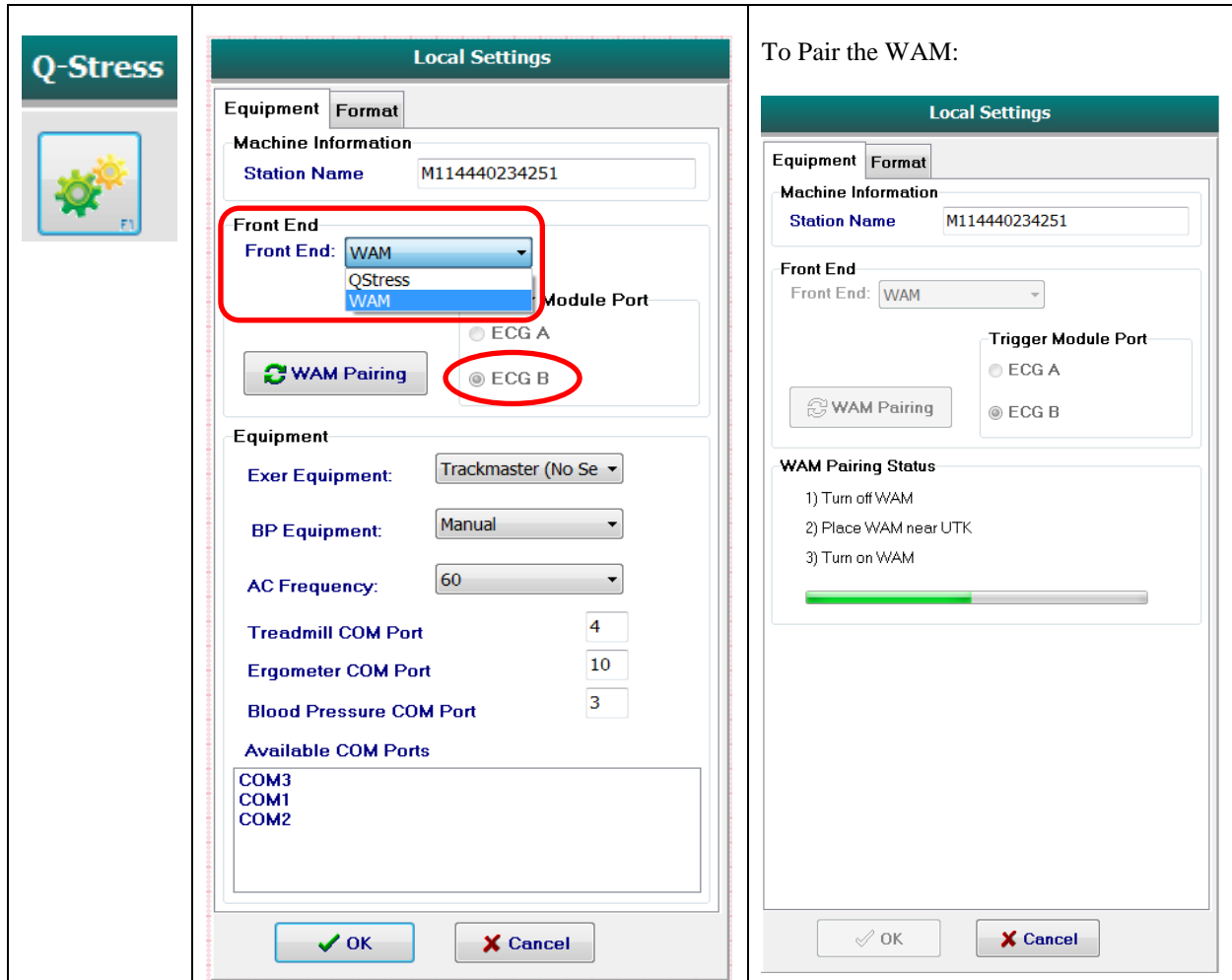

1. Connect simulator to WAM
2. In Front End box, select WAM.
3. Confirm when pairing WAM, Trigger Module port is set to ECG B.
4. Ensure that the UTK is connected to the ECG B port on the Trigger Module (if present).
5. If Q-Stress, ensure that the patient cable is connected to the AM12Q module and the AM12Q is connected
6. Make sure WAM unit is off
7. Select the **WAM Pairing** button.
8. Once the message pairing is shown, turn on WAM. If pairing is working will happen quickly. If pairing is still trying after 15 seconds, push Cancel pairing and turn off WAM. Repeat WAM Pairing process until WAM is successfully pair. WAM pairing could take several tries to get connected.

Once finished and an ECG simulator has been connected, you will see the simulated waveform on the display.

If NOT using Tango BP system:

1. Choose the proper Equipment from the drop-down lists
 - Set Exer Equipment is set to proper treadmill (TM55, TM65) or Trackmaster NO SOURCE if not using treadmill
 - If using treadmill, make sure Treadmill **COM port is set to 1**
 - If using Ergometer, make sure Ergometer COM port matches port # used to connect Ergometer
 - BP Equipment is set to Manual
 - AC frequency is set to local frequency of 50 or 60 Hz

Equipment

Exer Equipment: Trackmaster (No Se ▾)

BP Equipment: Manual ▾

AC Frequency: 60 ▾

Treadmill COM Port 4

Ergometer COM Port 10

Blood Pressure COM Port 3

Available COM Ports

COM3
COM1
COM2

OK Cancel

If Treadmill fail error is present during pretest, always check what COM port the Treadmill is set to and confirm which COM port the Treadmill is connected to back of PC via Serial cable.

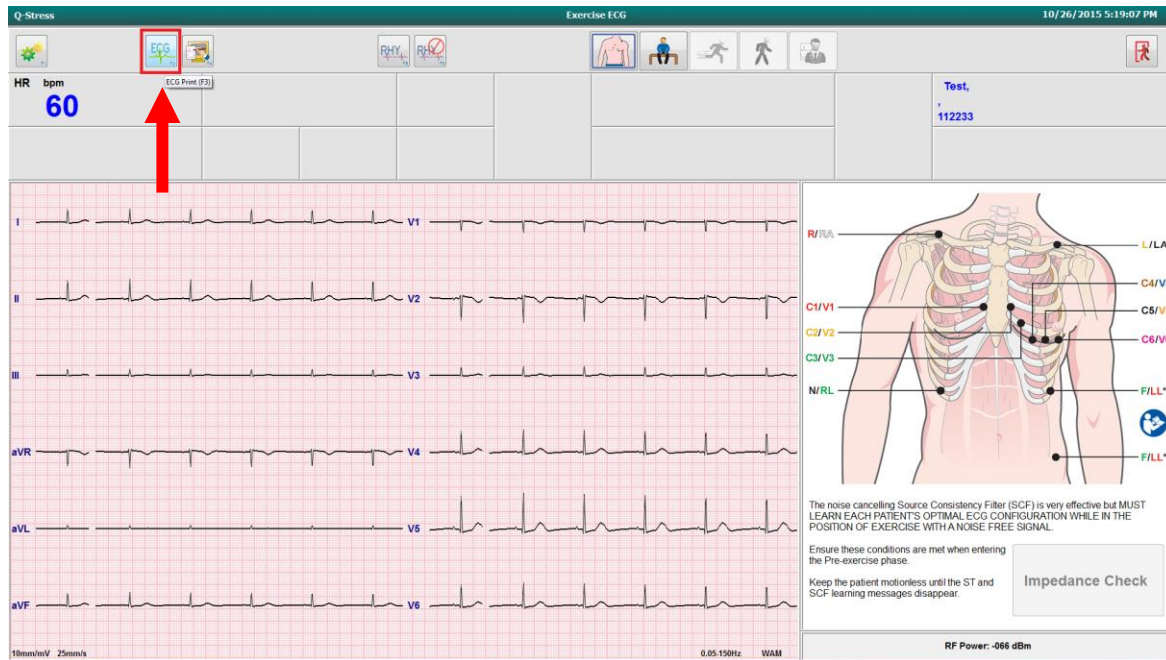

2. Select the **ECG** button and a 12-lead ECG will print to the configured printer (Z200+ thermal writer or Default Windows printer). Check/Adjust paper to make sure the edges are not getting crimped.
3. If you do not see waveforms check that the UTK is connected to the ECG B port on the Trigger Module if present.
4. Select the Pre-Exercise icon  to advance to Pre-Exercise.
5. Select BRUCE protocol (If no treadmill connected to Qstress, USE Pharmacology protocol)

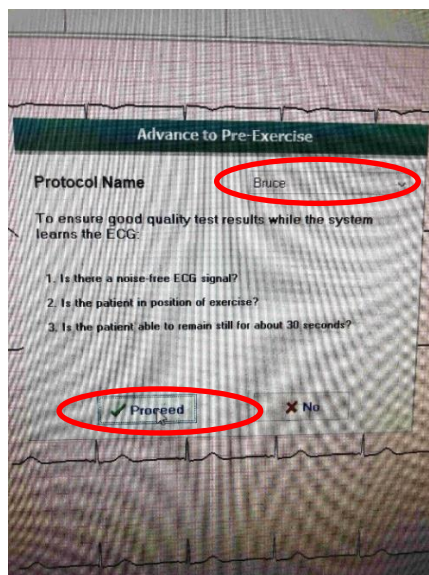

6. Click **PROCEED**

7. Wait for heartbeat to show up in middle square (this can take up to 45 seconds as the machine finds average heartbeat)
8. When the 3rd button (person exercising) turns to color, Select **Start Belt**

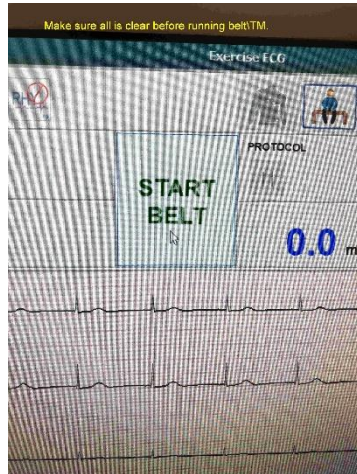

9. If treadmill is connected properly to Qstress it should turn on now. If not check that treadmill emergency stop button is not activated and that the treadmill cable is properly connected to Qstress computer. Ensure that the belt is moving according to the programmed speed and there is no "Treadmill Fail" message in the upper right area of the display.
10. With the treadmill running push the Emergency stop switch and verify that the treadmill does stop. After verify, turn the Emergency stop switch clockwise and verify that the switch pops up.
11. When 4th button is activated click it to end test
12. When 5th button is activated Click it to End Exam
13. **Exit** the *Start a Stress Test* display, and then click on the **Exit** button to exit the application.

Repeat for wired connection

1. Ensure that the patient cable is connected to the AM12Q module and the AM12Q is connected
2. Attach simulator to wired patient cable plugged into AM12Q
3. Click Qstress icon
4. Select Gear box to open settings
5. Select Qstress ECG A
6. Enter Test into field
7. Repeat test by repeating Steps 2-12 above

MAKE SURE to RESET back to WAM settings if a WAM unit is part of this install

If using Tango BP system:

- Choose the proper Equipment from the drop-down lists
 - Set Exer Equipment is set to proper treadmill (**TM55, TM65**) or **Trackmaster NO SOURCE** if not using treadmill
 - If using treadmill, make sure Treadmill COM port is set to **COM1**
 - If using Ergometer, make sure Ergometer COM port matches port # used to connect Ergometer
 - BP Equipment is set to **Tango M2** (or appropriate) BP monitor
 - Make sure BP COM Port is set to **COM2**
 - AC frequency is set to local frequency of 50 or 60 Hz

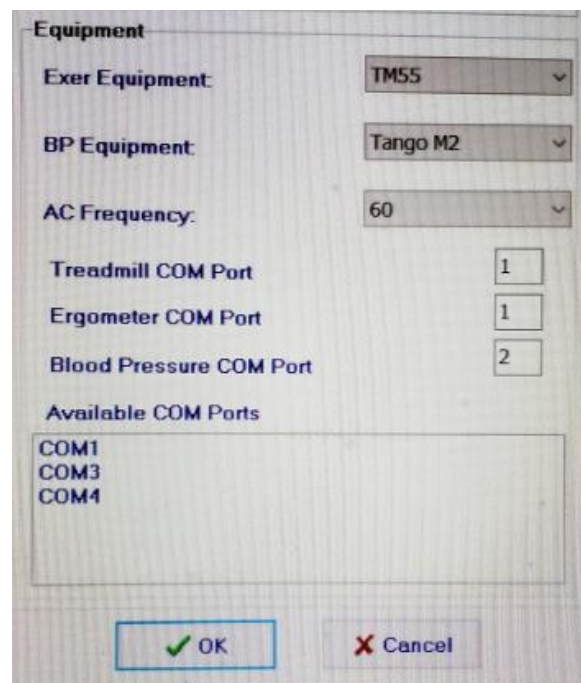

- Make sure Tango is set to XScibe using the Main Menu on Tango screen, as shown below.

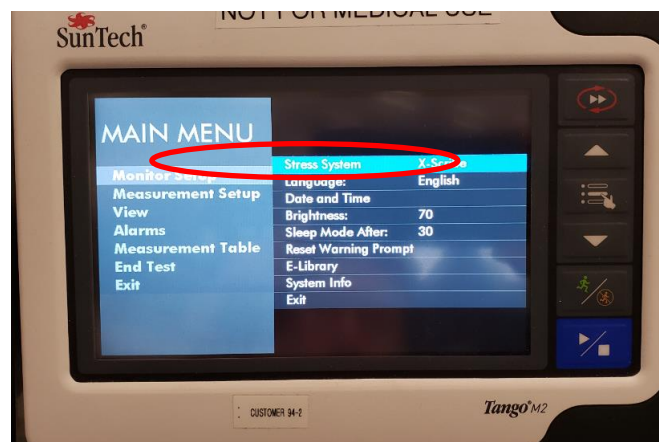

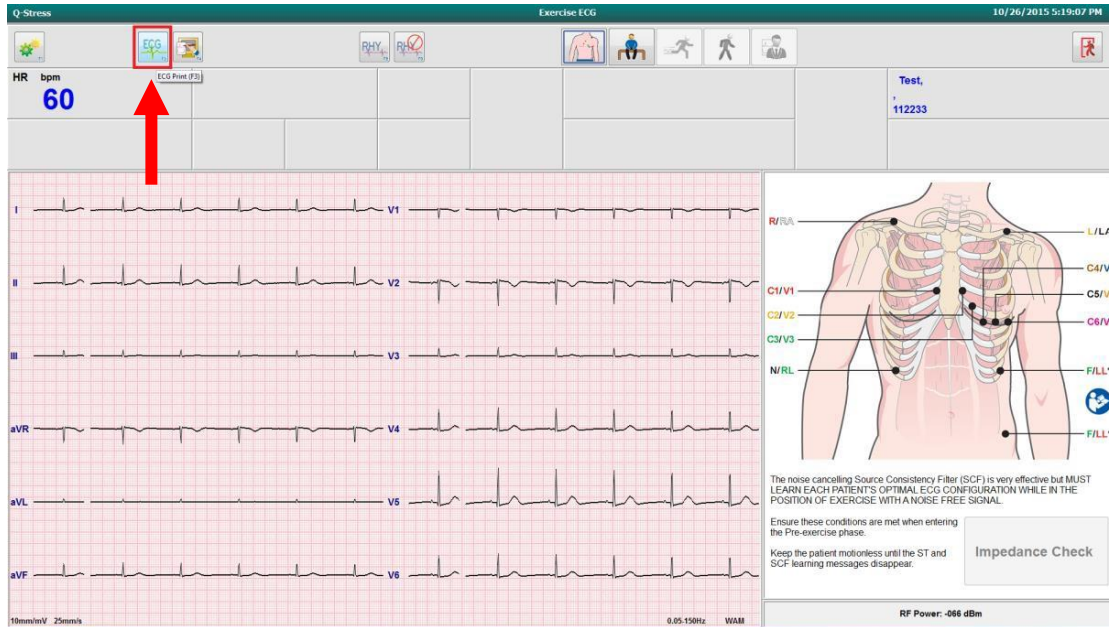

3. Select the **ECG** button and a 12-lead ECG will print to the configured printer (Z200+ thermal writer). Check/ Adjust paper to make sure the edges are not getting crimped.
4. If ECG waveforms are present, the system is connected using WAM. If no waveforms are present, then you would check the UTK port connection.
5. Select the Pre-Exercise icon  to advance to Pre-Exercise.
6. Select BRUCE protocol (If no treadmill connected to Qstress, USE Pharmacology protocol)

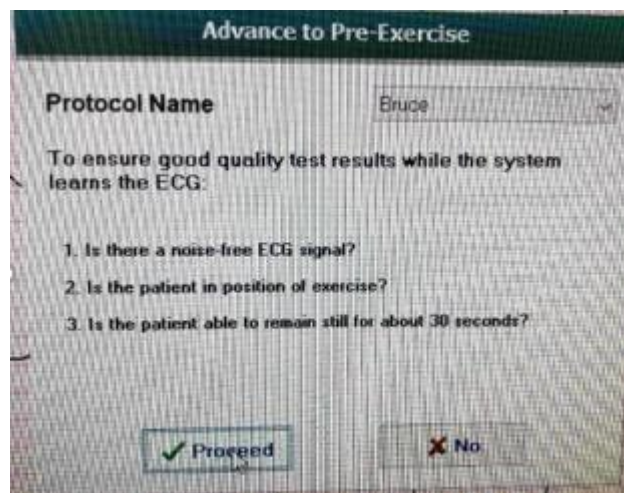

7. Click PROCEED

8. Wait for heartbeat to show up in middle square (this can take a little bit as the machine finds average heartbeat) up to 45 seconds
9. When the 3rd button is activated (person exercising) Icon will turn into color. Select start belt.
10. If treadmill is connected properly to Qstress it should turn on now. If not check that treadmill emergency stop button not activated and that cable is properly connected to Qstress. . Ensure that the belt is moving according to the programmed speed and there is no "Treadmill Fail" message in the upper right area of the display,
11. IF you are using a Tango BP cuff you should hear it noise coming from cuff as it inflates. IF no noise check BP cuff connections and tango unit operation per Manual in Tango unit box.
12. When 4th button is activated click it to end test
13. When 5th button is activated Click it to End Exam
14. **Exit** the *Start a Stress Test* display, and then click on the **Exit** button to exit the application.

Repeat for wired connection

1. Ensure that the patient cable is connected to the AM12Q module and the AM12Q is connected
2. Attach simulator to wired patient cable plugged into AM12Q
3. Click Qstress icon
4. Select Gear box to open settings
5. Select Qstress ECG A
6. Enter Test into field
7. Repeat test by repeating Steps 2-14 above

MAKE SURE to RESET back to WAM settings if a WAM unit is part of this install.

Section 5 – Troubleshooting (only needed if error below is encountered)

After rebooting the PC and launching the **Q-Stress Application**, you may experience the following error:

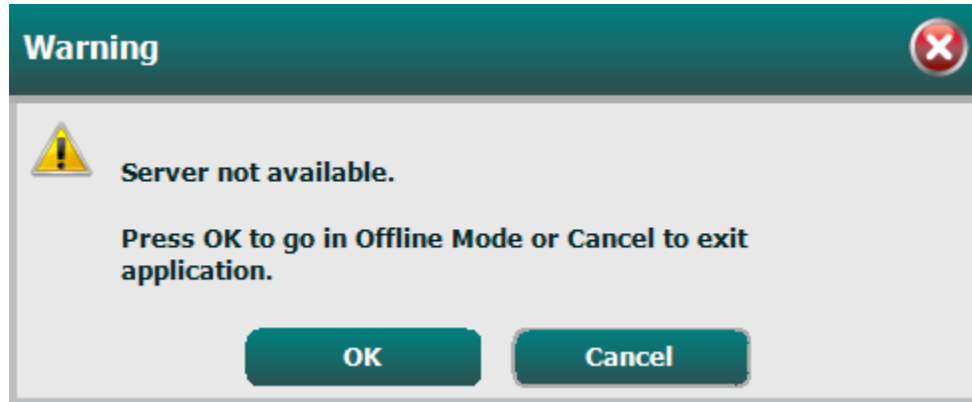

The **CorScribeDBSvc** used with **Q-Stress** can become unresponsive after the application software installation process has been completed. Since the **CorScribeAppServer** is dependent on the **CorScribeDBSvc**, this results in the user receiving a “**Server not available**” error message when attempting to login to the stress application.

Restarting the services manually will not restore normal operation.

To restore normal operation, stop the postgres processes, then delete the **postmaster.pid** file. Once this is accomplished, restart **CorScribeDBSvc** and **CorScribeAppServer** and **CorScribeLogServer**.

The steps below define how to perform the process:

1. Launch **Task Manager** with Administrative Rights from the Windows Start Menu.
2. Select the **Details** tab on the **Task Manager** as shown below.

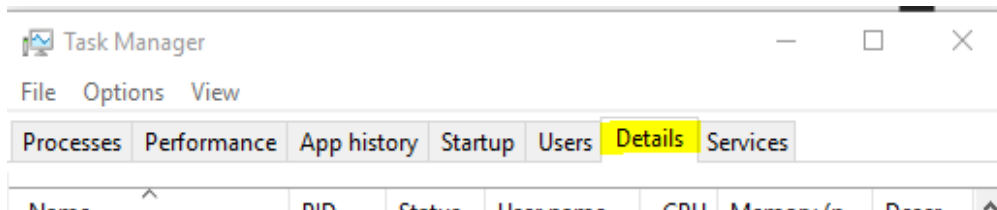

- Find the **postgres.exe** processes and click **End Task** on **all** the postgres processes.
(the number of postgres processes may vary from the example shown below)

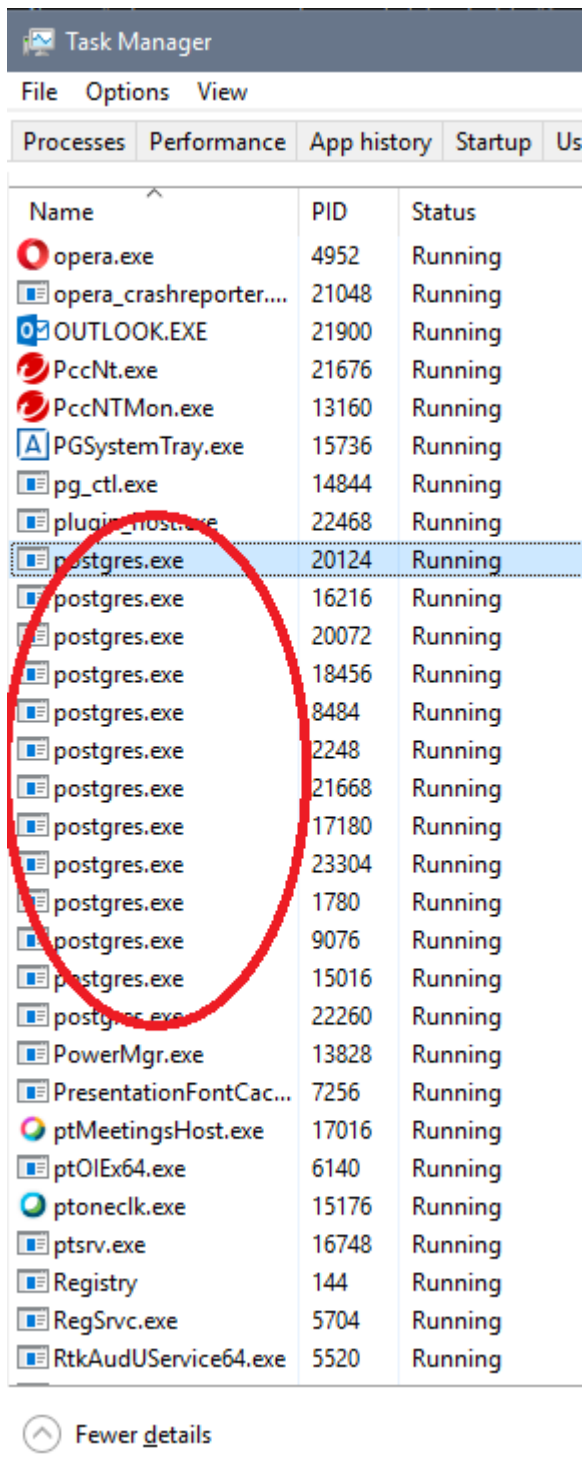

- Launch Windows Explorer.

5. Navigate to where the **postmaster.pid** file exists.
(Default directory is: **C:\ProgramData\MiPgSqlData\pgdata**)
6. Delete the **postmaster.pid** file
7. Launch the **Services** Application with Administrative Rights from the Windows Start Menu.

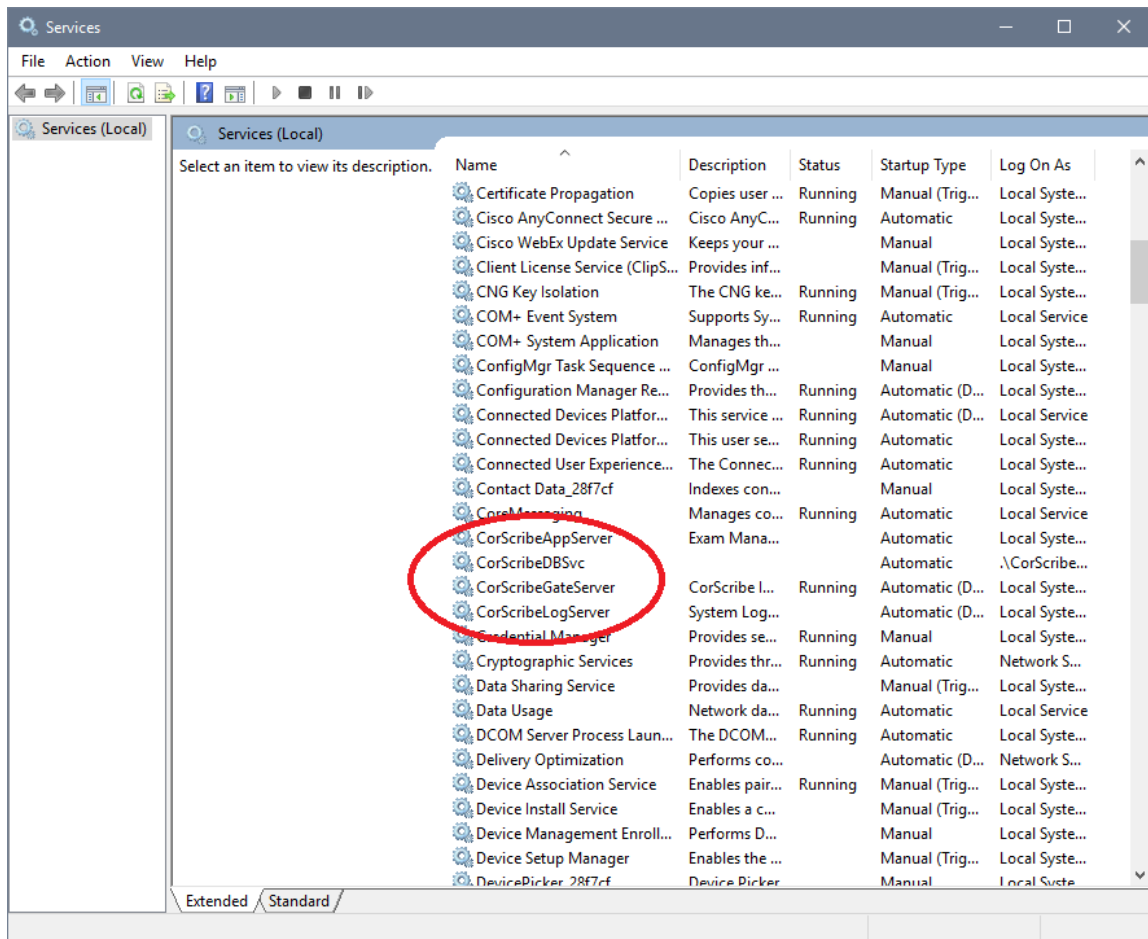

8. Right click on the **CorScribeDBSvc** and select Start
9. Right click on the **CorScribeAppServer** and select Start
10. Right click on the **CorScribeLogServer** and select Start
11. Visually verify that all **CorScribe** the services are running
12. Launch the **Q-Stress** application and verify that the **Server not available** message does not occur.